

FEBRUARY 2020



NFDA 2020 CALENDAR

Joint Conference & Tabletop Show with the Pacific-West Fastener Association

March 4-6, 2020

Westin Long Beach
Long Beach, California

Annual Meeting & Executive Sales Planning Sessions®

June 23-25, 2020

Embassy Suites Minneapolis
Downtown Minneapolis, Minnesota



PRESIDENT'S MESSAGE

By Doug Ruggles

I heard a story about a young boy who went to his mom and said "I need to write a report for school about penguins, can you help me?" The mom said "I don't know that much, ask your Dad." The boy replied "awe, never mind I don't want to know that much!" Sometimes I feel that way when talking about the benefits of the NFDA. I could go on and on but you guys have heard it all before. If you are reading this column, then you are interested already, but if it gets too much just yell "Penguins."

The NFDA Executive Summit was a wonderful event in Naples in November. Our speakers covered Import/Exports Compliance, Future of the Fastener Industry, Selling your Business, and Supply Chain. All the speakers were very educational. To highlight one, Adam Derry of Field Fasteners brought in a customer's supply chain executive to give us the voice of the customer. He discussed various topics of driving change to commodity leadership versus a transactional focus. His comment on fasteners are interesting but what we really care about is how it is used that's really important to your customers. Finding ways to improve your focus in this area was his recommendation and when you co-innovate with your customers, you'll have a winning combination. Also it was a pleasure to watch Jim Ruetz present the National Fastener Distributors Association's 2019 Fastener Professional of the Year award to Kevin Queenin of Specialty Bolt & Screw. Kevin's speech was an inspiration to us all. The sunset cruise hosted by *Distributor's Link* and Aluminum Fastener Supply was the highlight at the end of two days of education. My sincere thanks to all involved in setting up the event.

We have another opportunity to learn together on March 4-6 in Long Beach with the NFDA/Pac-West Joint Conference and Tabletop Show. Speakers lined up are economist Chris Thornberg, a session on strategic account management, a session on the digital distributor by Dr. Barry Lawrence from the ID program at Texas A&M, then on closing night a once in a lifetime event with dinner on board the USS Iowa! What an incredible line up. Don't get me started on the benefits of attending or someone will yell **PENGUINS**.

Membership incentive program: NFDA is in the membership business and we need your help to bring in new members. If you suggest a prospective NFDA member and they join, your dues will be credited \$1,000!

I also encourage your feedback, suggestions, ideas and / or comments to me at doug@martinsupply.com or you can reach me directly at 256-248-0412.

Remember: it's what you make of it!

SAVE THE DATE!



NFDA's Annual Meeting and Executive Sales Planning Sessions® will take place in Minneapolis, Minnesota, **June 23-25, 2020**. Look for details about this meeting on the website soon. **Save the Date!**

VISIT US AT FASTENER FAIR USA

Stop by the NFDA booth at the Charlotte Convention Center in Charlotte, North Carolina, **May 18-20 2020**.





ASSOCIATE CHAIR'S MESSAGE

By Kelly Charles

Welcome to 2020! I hope everyone had a healthy and happy holiday season.

I am looking forward to all that 2020 has in store for us. Even though there is a lot of uncertainty in our current business climate, you can find reassurance in the upcoming programming the NFDA has planned for our members.

First up, the 2020 Joint Conference and Tabletop Show with Pac-West, March 4-6 in Long Beach, CA. We have great programming, including Dr. Thornburg with his update on the economy. I am especially looking forward to the port tour and dinner aboard the USS Iowa, as well as the tabletop show. The deadline for the best registration rate is February 19, 2020.

Next up is the Annual Meeting & ESPS® in Minneapolis, June 23-25, 2020. We have expanded the ESPS® to a day and half, to help make sure you are able to set the appointments most important to you. Be sure to take advantage of all the networking opportunities available.

Here's to a great 2020!
See you soon!

NOMINATIONS FOR FASTENER PROFESSIONAL OF THE YEAR AWARD

The National Fastener Distributors Association is now accepting nominations for the 2020 Fastener Professional of the Year award.

Created in 2017, the award recognizes individuals who make exceptional contributions to their companies and to the fastener industry. The inaugural award was presented to Robbie Gilchrist of Capital Marketing (High Point, North Carolina). The 2018 award recipient was Jim Ruetz of AIS (Franksville, Wisconsin) and the 2019 award recipient was Kevin Queenin of Specialty Bolt & Screw (Agawam, Massachusetts).

Membership in NFDA is not a requirement to be selected for the Fastener Professional of the Year award. Self-nominations are acceptable, or nominations can be submitted by others.

The deadline to submit nominations for the 2020 award is February 21, 2020. The award will be presented at the NFDA Annual Meeting, June 23-25, 2020 at the Embassy Suites Minneapolis Downtown in Minneapolis, Minnesota.

The nomination form can be found at nfda-fastener.org



FASTENER TRAINING INSTITUTE

FASTENER TRAINING OPPORTUNITIES

The Fastener Training Institute® offers the following opportunities to increase your fastener knowledge:

FEBRUARY 6 – Fastener Basics - Union City, CA

FEBRUARY 13 – Product Training Part 2 – Costa Mesa, CA

MARCH 12 – Product Training Part 3 – Costa Mesa, CA

NFDA members receive discounted registration on all FTI classroom seminars. For more information and a list of all FTI events visit www.fastenertraining.org



SCHOLARSHIPS FOR FASTENER TRAINING WEEK

Twice each year NFDA awards a scholarship for Fastener Training Week, an advanced technical training program produced by the Fastener Training Institute®.

Applicants are evaluated based on the recommendation from their employer, personal achievements, work experience, and an essay. Identifying information is redacted, so the team evaluating the applications does not know the names or employers of those applying.

Fastener Training Week scholarships are a benefit for NFDA members only. The next deadline to apply for a scholarship is **JUNE 1, 2020**. The application can be found at nfda-fastener.org/fastener-training-week-scholarship. Apply today!

For more information about Fastener Training Week, visit www.fastenertraining.org



PROFIT REPORT

The annual NFDA Profit Report presents a detailed but straightforward analysis of financial and operating characteristics of participating fastener firms. Results are presented in tables and graphs designed to provide a comprehensive guide for analyzing profitability.

The 2020 NFDA Profit Report Survey will be sent to all NFDA members in April. If you participate in the survey, you will receive the Profit Report for free (normally \$250 for members, \$500 for non-members).



**MARCH 8-11, 2020
INDIANAPOLIS, IN**

PRESENTED BY
aea
association education alliance
INNOVATION THROUGH COLLABORATION

WITH THE SUPPORT OF
PURDUE
UNIVERSITY



NFDA OFFERS SCHOLARSHIP TO UNIVERSITY OF INNOVATIVE DISTRIBUTION

March 8-11, 2020 | Indianapolis, Indiana

The University of Innovative Distribution (UID) is a concentrated educational program focused on the unique needs of the wholesale distribution industry. Known worldwide for excellence in education, UID is sponsored by the Association Education Alliance (AEA) a consortium of 40+ distribution professional associations, in cooperation with the Department of Technology Leadership and Innovation of Purdue University. Working together, these groups take great pride in providing a superior learning experience.

NFDA members are eligible for a \$1,000 discount on the registration fee for this week-long program. Plus, this year we will offer one scholarship for the full registration fee.

To apply for the scholarship call 562-799-5519, for an application form. The deadline to apply is **FEBRUARY 3**.

For more details about UID, visit www.univid.org

Education tracks cover foundational, intermediate, and advanced classes in the following education tracks:

Leadership / Professional Development

Distribution Strategy

Management (Including HR)

Sales

Marketing

Operations

**WELCOME
NEW NFDA
MEMBERS**

KPF USA
kpf-global.com

Centennial Bolt, Inc.
centennialbolt.com

MARKET YOUR BUSINESS ◆ THROUGH NFDA ◆

Interested in having an insert about your company in the next issue of NFDA Today? Contact Amy Nijjar to make the arrangements: amy@nfda-fastener.org or 562-799-5519. You also can view information on our website. Click on Advertising in the menu.

NFDA FASTENER STANDARDS ACTIVITY UPDATE – Q4 2019

By John Medcalf

The fourth quarter of 2019 saw plenty of work on fastener standards, many of the topics being familiar subjects in this column. The ISO fastener committee meetings were held in Lyon, France in October, and ASTM met in Houston, TX in November. A few updates are as follows:

ISO TC2

- The revision of ISO 898-1 on mechanical properties of externally threaded fasteners was discussed with topics including resolving an issue with tensile stress areas, surface hardness testing, impact testing, and martensite requirements among others. This will be a main topic of discussion in ad hoc group meetings in 2020.
- ISO 16047, a test method for measuring torque-tension performance of fasteners, has been decided to be revised. It will be split into two parts, with the priority placed on part one, which should become a clear reference method with better defined reference parts, cleaning methods, calculation methods, and other parameters.
- After many years of meetings and discussions, the revision to ISO 898-2 on mechanical properties of internally threaded fasteners is moving through the ballot process. The main theme of the revision is updates to hardness values to prevent thread stripping in the various combinations of property classes and nut geometries.
- A fair amount of discussion is occurring around ISO 2702 on self-tapping screws. Refinements to hardness levels and their compatibility with electroplating are being reviewed.
- A new working group will be formed to further the work on ISO standards for pre-applied adhesives, thread lockers, and sealants.
- Ad hoc meetings will occur in Paris in February 2020 to move many of these projects forward.

ASTM F16

- ASTM F606/F606M on test methods still has two projects open – the addition of charpy impact testing and updates to the hydrogen embrittlement test method. The HE test project is expected to be coordinated with ISO work on the same subject.
- The combined zinc-flake coating specification finally reached consensus, and should proceed to publication shortly.
- ASTM F1941/F1941M on electroplating and ASTM F2329/F2329M on hot dip galvanizing will both be comprehensively reviewed for revisions.

- The project to combine ASTM A563 inch and metric nut standards continues, but is getting closer to completion. It represents significant updates, similar to the combination of the structural bolting standards.

- Work is underway to reinvigorate subcommittee F16.96 on Bolting Technology. The general intent of the subcommittee is to be a venue to advance general knowledge on fastening topics. The goal will be to increase engagement with fastener users to get a better cross-section of knowledge and experience.

John Medcalf is Principle Engineer for Peak Innovations Engineering and is NFDA's technical representative.

Communication between NFDA members and the NFDA technical standard representative (the "Representative") through email or otherwise is provided by NFDA as a courtesy to its members. NFDA provides no assurance as to the accuracy, completeness, or timeliness of any statement made by the Representative to the member or fastener technical standards organizations. Neither NFDA nor the Representative makes any representation as to whether any statement of the Representative is consistent or compliant with fastener technical standards. Neither NFDA nor the Representative shall be responsible for any loss or damage suffered by the member or any other person as the direct or indirect result of any statement made by the Representative.

John Medcalf's appointment as the NFDA technical standards representative allows the NFDA membership not just visibility of standards activities, but also a voice in the process.

NFDA members are encouraged to express their comments or concerns relating to fastener standards. The only way to influence the process is to stay engaged and participate.

MEMBERS CAN:

- Inquire about changes to drafts noted in quarterly reports
- Raise suggested revisions or technical updates to standards
- Ask general standards related questions
- Offer feedback to continue refinement of these articles

Please email your standards related comments, concerns or questions to John at:
standards@nfda-fastener.org



3020 Old Ranch Parkway Suite 300
Seal Beach CA 90740
562-799-5519
www.nfda-fastener.org

VICKIE LESTER
Executive Vice President
vlester@nfda-fastener.org



KKC1FN

FOAM NITRILE



KKC1PU

POLYURETHANE



KKC2FN

FOAM NITRILE



KKC2PU

POLYURETHANE



KKC2PU-Y

POLYURETHANE



KKC3FN

FOAM NITRILE



KKC3KV

FOAM NITRILE

DuPont™
Kevlar.



KKC4FN

FOAM NITRILE



KKC4PU

POLYURETHANE



KKC4N

FLAT NITRILE



KKC5KV

FOAM NITRILE

DuPont™
Kevlar.



KKC6FN

FOAM NITRILE



TAKE

COMMAND™

Ironclad
PERFORMANCE WEAR®



Ironclad
Wet Grip Nitrile
K10CAFN
ANSI 105
EN 388
CE
CUT A4
XL110
4443E

**TOUCHSCREEN.
MEET CUT RESISTANCE.**

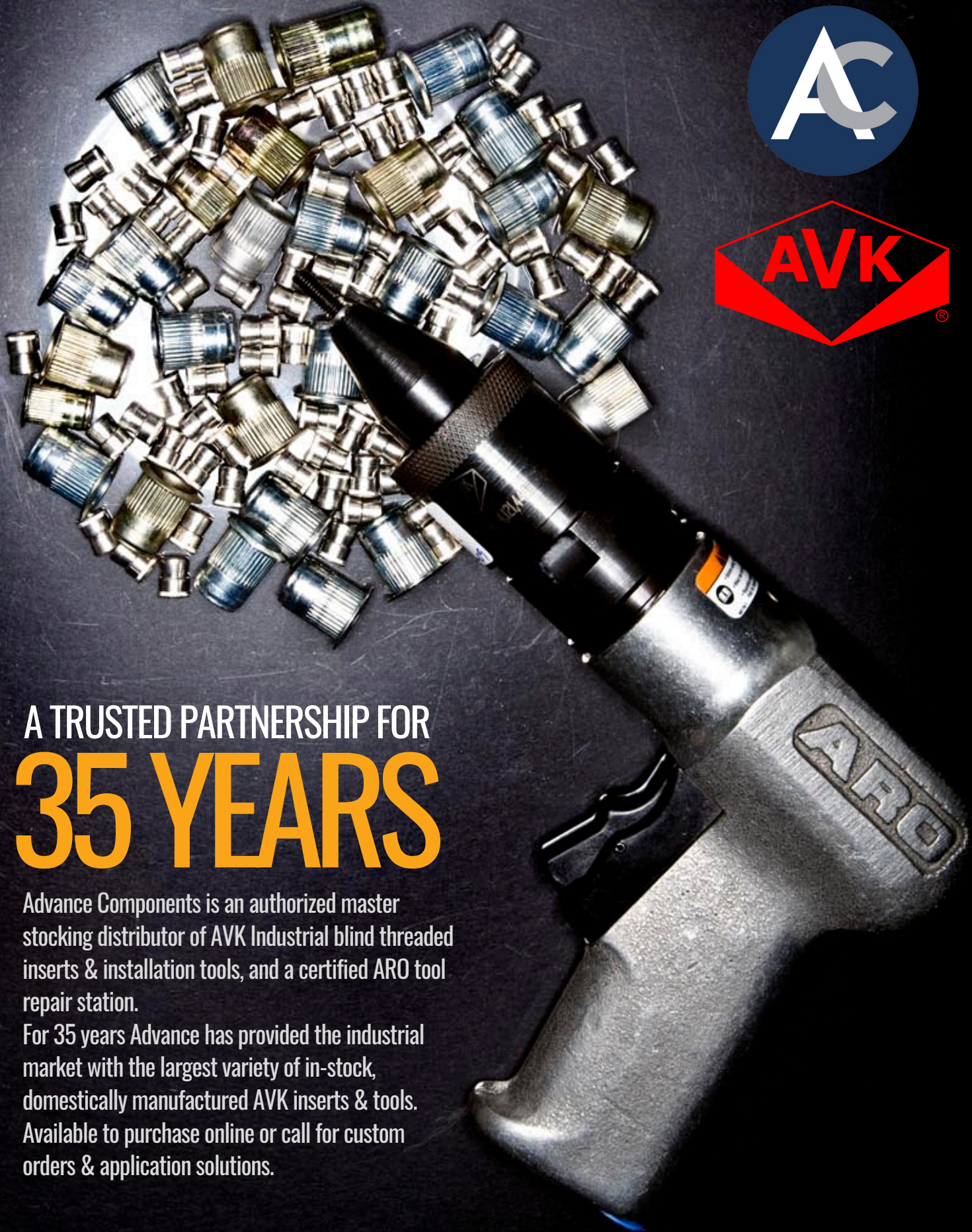

A TRUSTED PARTNERSHIP FOR 35 YEARS

Advance Components is an authorized master stocking distributor of AVK Industrial blind threaded inserts & installation tools, and a certified ARO tool repair station.

For 35 years Advance has provided the industrial market with the largest variety of in-stock, domestically manufactured AVK inserts & tools. Available to purchase online or call for custom orders & application solutions.

ADVANCECOMPONENTS.COM

972.446.5500



2020 EXPANSION

Rare Parts. Right Now.

80,000 MORE SQ. FEET | EXPANDING FROM 50 TO 60 FULLY AUTOMATIC SWISS LATHES



24/7/365 LIGHTS OUT PRODUCTION | 2,000,000 PARTS PER MONTH CAPACITY



Search our online catalog at ampg.com.

8090 Woodland Drive | p: 317.472.9000
Indianapolis, IN 46278 | f: 317.472.9010

CUSTOM FASTENERS

HUGE INVENTORY. MADE TO ORDER. FAST.

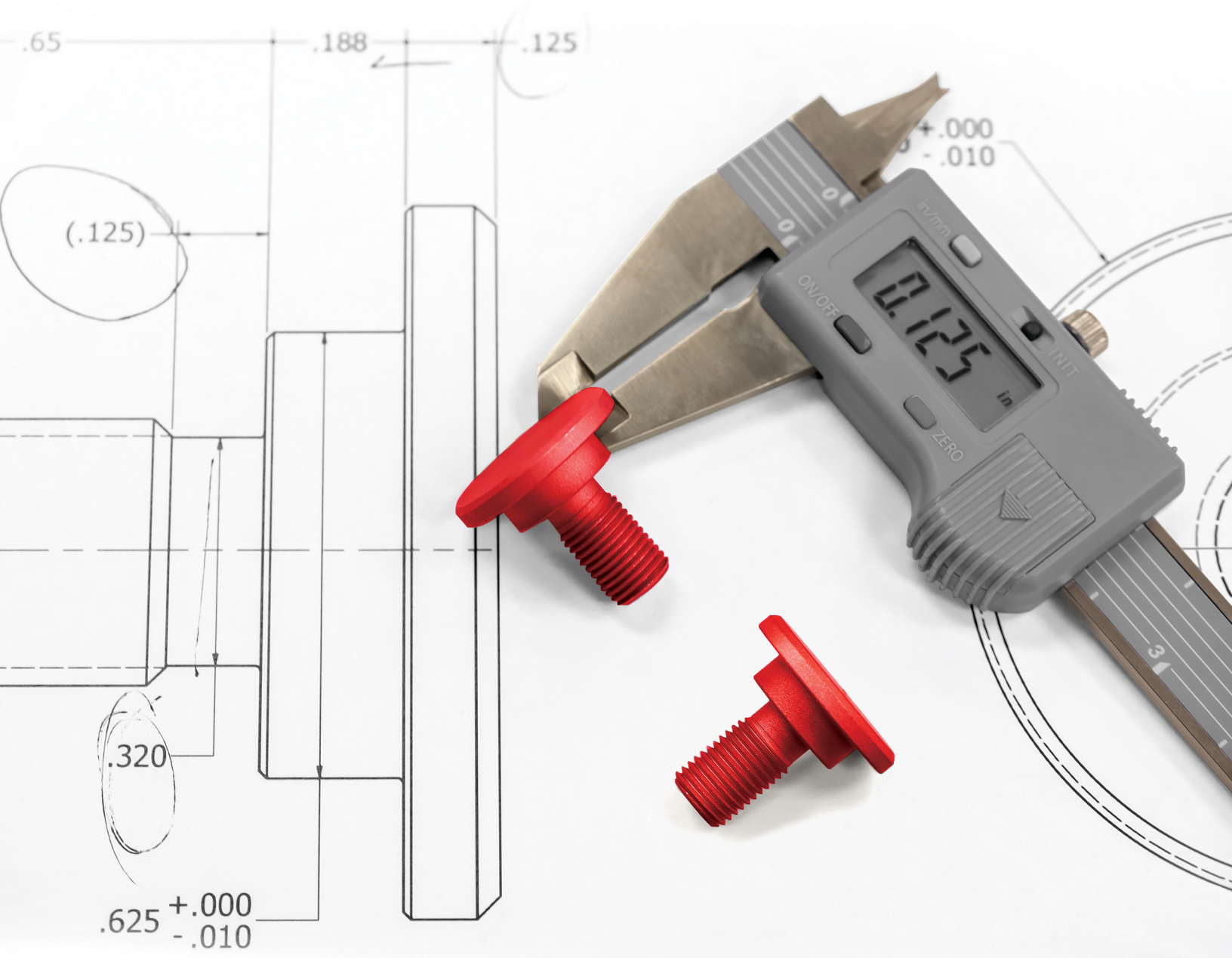

PRINT TO PART IN 7 DAYS | MADE IN INDIANAPOLIS

AMPG
www.ampg.com



Search our beautiful fasteners at ampg.com.

8090 Woodland Drive | p: 317.472.9000
Indianapolis, IN 46278 | f: 317.472.9010

**We expanded
our metric line.**
**NOW shipping
Metric Hex Head
Cap Screws and
Metric Tap Bolts.**

BACKED BY THE EARNEST
Service
GUARANTEE

OUR PROMISE TO YOU...

If we send you the wrong part,
enter your order incorrectly,
short you on quantity, or deliver
a priority shipment late, not
only will we make it right,
we'll credit your account \$50.



Earnest

How can we help you today?

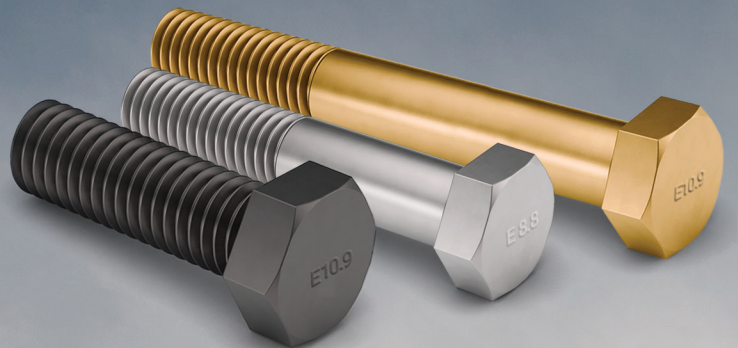

DIN Spec Metric Hex Head Cap Screws stocked in sizes
M6 thru M36. ISO Spec stocked in M5 thru M24.
Custom plating and blanks for custom rework up to M42
available. For details visit EarnestMachine.com or
call 800.327.6378.





How can we help you today?

EARNEST MACHINE'S FULL METRIC LINE

METRIC CARRIAGE BOLTS

Carriage Bolt
Short Neck Carriage Bolt

METRIC HEX HEAD BOLTS

Hex Head Bolt
Hex Head Tap Bolt

HARD-TO-FIND METRIC PARTS

Left Handed Cap Screw
Track Shoe Bolts
Place Bolt - Type AA
Wheel Bolt
Serrated Shoulder Wheel Bolt

METRIC SCREWS

Hex Head Cap Screw
Hex Flange Screw
12-Point Flange Screw
Socket Head Cap Screw
Socket Low Head Cap Screw
Socket Head Shoulder Screw
Socket Cap Screw
Button Head Socket Cap Screw
Flange Button Head Cap Screw
Socket Set Screw

METRIC NUTS

Heavy Hex Nut
Hex Nut - Import
Hex Flange Nut
Hex Flange Lock Nut
Hex Lock Nut (M)
Nylon Insert Hex Flange Lock Nut
Regular Square Nut
Weld Nut
All Metal Lock Nut
Wheel Nut

BACKED BY THE EARNEST

Service
GUARANTEE

OUR PROMISE TO YOU... If we send you the wrong part, enter your order incorrectly, short you a quantity, or deliver a priority shipment late, not only will we make it right, **WE'LL CREDIT YOUR ACCOUNT \$50.**



***DISTRIBUTOR FOCUSED.
QUALITY DRIVEN.
TIME TESTED.***



***WWW.ELGINFASTENERS.COM
FASTENER HOTLINE: 812.689.8990***



7 BRANDS 1 PURPOSE

TO SUPPORT OUR DISTRIBUTORS WITH THE WIDEST
PRODUCT OFFERING, BEST DELIVERY AND HIGHEST
QUALITY FASTENER SOLUTIONS AVAILABLE.



TRUSTED
BY DISTRIBUTORS LARGE AND SMALL
FOR DELIVERING THE HIGHEST QUALITY
SPECIALTY FASTENERS



MORE THAN
1.3 BILLION
PARTS SHIPPED ANNUALLY



SPECIALTY FASTENERS AND WIRE FORMS
MADE TO PRINT WITH IN-HOUSE ENGINEERING
SUPPORT AND DESIGN HELP

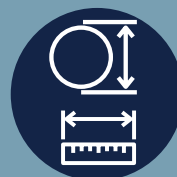

**BOLTS, SCREWS, RODS,
STUDS AND NUTS**

- FROM 3/16" TO 96" IN LENGTH
- 1/4" TO 1 1/4" IN DIAMETER
- NUTS FROM 1/4" TO 7/8"
- METRIC OPTIONS ASLO AVAILABLE

WIRE FORMS

- CUSTOM CNC CAPABILITIES
- 3/32" TO 1" IN DIAMETER
- 1/2" TO 144" IN LENGTH



WWW.ELGINFASTENERS.COM
FASTENER HOTLINE: 812.689.8990





MASTER DISTRIBUTOR OF INDUSTRIAL SKIN CRAFT

What is Industrial Skin Craft?

Rivet nuts are designed to provide strong load-bearing threaded connections in thin gauge materials, or "skins," when threading is not an option. With the advent of newer materials that reduce product weight or increase strength, designs for "skinning" industrial and commercial objects have become ever more sophisticated. Industrial skinning has become a craft, and G.L. Huyett is well-positioned to support the supply chain for industrial skin craft.

Full Line of Materials and Body Styles In Stock, Ready to Ship!



- Safety Stock
- Technical Support
- Competitive Pricing
- Broken-Box Small Order Fulfillment
- Easy Ordering
- MIL-SPEC

Your House of Representatives

Contact your knowledgeable and experienced sales representative for assistance in product selection, technical support, and world class customer service.



Dan Harriger VP - Sales North America	Chris Bell Southwest Region	Dewey Oxner Mid-Atlantic Region	Dave Audia New England Region	Jason Mizner Rocky Mountain Region	Jim Flannery Midwest Region	Terry May Prowest Marketing, Inc. Northwest Region
---	-----------------------------------	---------------------------------------	-------------------------------------	--	-----------------------------------	---

We Proudly Distribute:



Free Certifications*

Visit huyett.com/MyAccount/OrderHistory to download FREE Material, Compliance, and RoHS/REACH Certifications.



CONTACT G.L. HUYETT TODAY! SALES@HUYETT.COM | 785-392-3017 | WWW.HUYETT.COM





MANUFACTURER & MASTER DISTRIBUTOR



LOW MINIMUMS ■ GREAT PRICES ■ EASY ORDERING



PINS & WIREFORMS

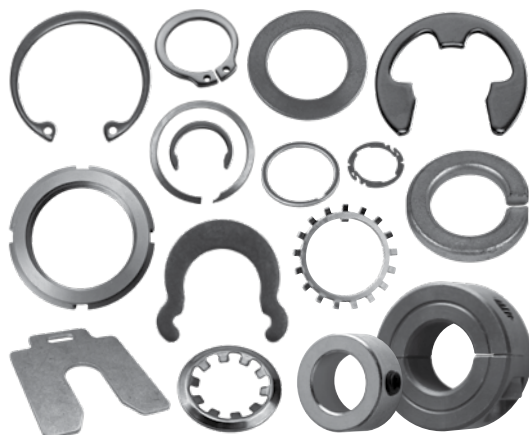

RETAINING RINGS, CLIPS, COLLARS, WASHERS, & SHIMS

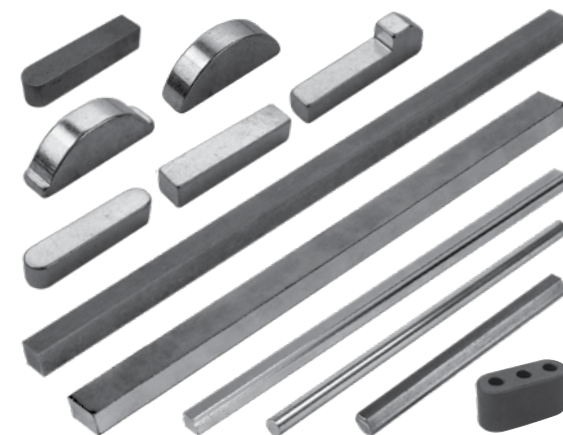

KEY STOCK & MACHINE KEYS



GREASE FITTINGS & ACCESSORIES



PREMIUM LIFTING HARDWARE



ENGINEERED FASTENERS



sales@huyett.com | 785-392-3017 | www.huyett.com

* SOME EXCLUSIONS APPLY