

NFDA TODAY: Your National Fastener News

May 2019



President's Message

By Kelly Cole

We've just concluded our joint conference with MWFA and Pac-West in beautiful San Diego. It was a spectacular event. Attendance was one of the highest on record. Thank you for your support. It was a blast sharing my family moment there. Introducing them was a highlight for me. I want to thank everyone in attendance for recognizing and sharing your thoughts with us. Thank you.

Another big highlight of our time in San Diego was honoring our 2018 Fastener Professional of the Year, Jim Ruetz. I offer my best wishes for the new phase in Jim's life. He will remain busy working on a doctorate degree and consulting. We look forward to seeing him and his family at more events for many years. Good luck Jim.

We have a change in leadership on the NFDA Board of Directors. The parent company of Trinity Supply Logistics has asked Dan Zehnder to take on a bigger role, that will require his relocation to Spain for part of the year. Poor guy! Realizing this would not be fair to NFDA, Dan reluctantly resigned and the Board approved moving Doug Ruggles of Martin Supply to take on vice president responsibilities. As is NFDA's tradition, Doug will assume the role of NFDA president when my term ends in June.

We've also had a change in the associate chair position on the Board. Bruce Hayes at Sems and Specials asked to step down, and I'm pleased to announce that Kelly Charles (also at Sems and Specials) is filling in.

This has been a very quick year for me. Business remains strong and the political climate is always creating challenges, but all in all, NFDA is poised for gains in many areas. Membership retention is off the charts, attendance is up at meetings, and membership value is ever present. It shows by the positive feedback and networking opportunities members continue to take advantage of.

Looking ahead to the summer months, it is time to get the calendars out and get planning. The annual meeting will be June 10-11 in Cincinnati. Although the Reds are not in town those days, we will find some time to have some fun (perhaps at the Over the Rhine breweries) as well as get our annual economic injections from ITR and Alan Beaulieu. I am really looking forward to seeing how the 2019 and 2020 forecasts shape up.

Well, I'm off on vacation. Email just got disconnected. I'm out. See you in Cincinnati!

Best regards,

Kelly Cole



Associate Chair's Message

By Kelly Charles

I would like to thank Kelly Cole and the rest of the board for welcoming me as the associate chair. I have big shoes to fill (literally and figuratively, Bruce Hayes!) I am looking forward to serving on the board and advancing the goals of NFDA.

We are coming off a great joint meeting with Pac-West and MWFA. The programming was relevant and engaging, and the conference allowed for many networking opportunities. I especially enjoyed the roundtable session. Plus, as a Midwesterner, it was hard to argue with the beautiful San Diego weather!

Mark your calendars for the June annual meeting, sponsored by the North Coast Fastener Association, June 10-11 in Cincinnati, Ohio. I look forward to seeing you there!

Kelly

In This Issue

- President's Message
- Associate Chair's Message
- Annual Meeting
- Member Benefit Spotlight
- Training Opportunities
- Fastener Standards Update
- Scholarship Opportunities
- Joint Conference Photos

NFDA Calendar

- Fastener Fair USA**
May 22-23, 2019
Cobo Center, Detroit, Michigan
- Fastener Tech '19**
June 3-5, 2019
Donald E. Stephens Convention Center, Rosemont, Illinois
- Annual Meeting**
June 10-11, 2019
Hilton Cincinnati Netherland Plaza
Cincinnati, Ohio
- International Fastener Expo**
September 17-19, 2019
Mandalay Bay Convention Center
Las Vegas, Nevada
- Executive Summit**
November 3-5, 2019
Ritz-Carlton Beach Resort
Naples, Florida
- Joint Conference & Tabletop Show**
March 4-6, 2020
Westin Long Beach
Long Beach, California
Tabletop Show and joint meeting with the Pacific-West Fastener Assoc.

Join us in Cincinnati!

The NFDA 2019 Annual Meeting will take place at the Hilton Cincinnati Netherland Plaza, June 10-11, 2019.

In addition to roundtable discussions, this meeting will feature some great educational sessions. Brian Friedle of MITS will share how distributors can boost profitability by utilizing their data and how to choose a platform with the most benefits. Heather Stewart of Wurth Industry North America will discuss supply chain transparency. She'll note the implications of transparency and how to be prepared. Matt Johnson of Spinstak Growth Agency will present the session "Industrial Marketing 101" where you'll learn how to start thinking more like marketers and less like order-takers.

And as usual for the annual meetings, we'll have an economic update from Alan Beaulieu of ITR Economics. Alan will provide insight into where the global economy is heading and how it will impact your business.

Join us! For more details and to register online, check the website, nfda-fastener.org



Member Benefit Spotlight

Fastener Training Institute Education

As a special benefit for NFDA members, the Fastener Training Institute® (FTI) offers discounts on all their classroom courses and the Online Learning Library. FTI programs range from basic information for new employees to advanced technical subjects taught by industry experts.

The newly launched Online Learning Library allows your staff to train at their own pace. There are more than 30 training videos available covering topics to fit every employee's needs. And annual subscriptions are available at a substantial discount for NFDA members.

Find the schedule of upcoming classes and more information about training on their website at fastenertraining.org. Another benefit of NFDA membership!



FASTENER
TRAINING
INSTITUTE

Training Opportunities

The Fastener Training Institute® has the following upcoming opportunities to increase your fastener knowledge:

- May 14 - Fastener Manufacturing Plant Tours – Los Angeles Area
- May 17 – Webinar: My Major Customer Has A Quality Concern – Online
- May 21 - Fastening 101: Understanding Threaded Fasteners with Emphasis on the Automotive Market - Detroit, MI (at Fastener Fair)
- June 3 - Why Fasteners Fail - Chicago, IL (FastenerTech '19)
- June 11 - Fastener Secondary Process Plant Tours – Los Angeles Area
- June 19-21 - Understanding Hydrogen Embrittlement in Fasteners - Wixom, MI
- June 21 – Webinar: Aerospace Fasteners - An Overview and How They Differ from the Industrial Fastener – Online
- July 16 - Dimensional and Material Specifications - Costa Mesa, CA
- July 19 – Webinar: Distributor Quality Assurance - Intro to ISO and AS for Fastener Suppliers – Online

NFDA members receive discounted registration on all FTI classroom seminars.

For more information and a list of all FTI events visit fastenertraining.org

Save the Date!



Mark your calendars now for NFDA's 2019 Executive Summit.

Located at the Ritz-Carlton Beach Resort in beautiful Naples, Florida, this will be an event you won't want to miss!

Complete details about this November 3-5 event will be on the website in June.

See you there!



3020 Old Ranch Parkway Suite 300
Seal Beach, CA 90740
562-799-5519
www.nfda-fastener.org

Vickie Lester

Executive Vice President
[vl Ester@nfda-fastener.org](mailto:vl Lester@nfda-fastener.org)

Jeannine Christensen

Meetings/Events Director
jchristensen@nfda-fastener.org

NFDA Fastener Standards Activity Update - Q1 2019

By John Medcalf

While there haven't been any meetings since the last update, there have been some significant developments in the field of hydrogen embrittlement. The first is the publication of ISO/TR 20491: *Fasteners - Fundamentals of Hydrogen Embrittlement in Steel Fasteners*. I have commented on the development of this document over the last few years and believe it is a significant document for the fastener industry. Starting life as a white paper published by Salim Brahim (Technical Director of IFI), the document went through painstaking review by the international community of fastener experts. As an ISO technical report, it reflects the most current global fastener industry know-how regarding the phenomenon – including material susceptibility, hydrogen damage mechanisms, baking, testing, and other topics. For anyone seeking knowledge, or to educate a customer or supplier, I recommend reviewing the document. It can be purchased from the IFI web store at: www.indfast.org/shop/display_products.asp?cat=2

The second major development is the approval and publishing of the revision to ASTM B633 on electroplating (ASTM B633-19). Since the 2007 revision, the standard had required baking of parts with a strength above 1,000 MPa (or hardness above 31 HRC). This would include fasteners such as SAE J429 Grade 5, or ISO 898-1 property class 8.8, which have no susceptibility to hydrogen embrittlement. In addition, the standard was in direct conflict with ASTM F1941/F1941M, which does not mandate baking until hardness exceeds HRC 39. The situation has caused confusion, at best, and lawsuits related to flawed failure analyses at worst. With the 2019 revision, ASTM B633 contains baking requirements that are once again in line with ASTM F1941/F1941M.

Upcoming meetings include ISO ad-hoc meetings in France in early April to discuss the ISO 16047 torque-tension testing standard and ISO 898-1 and 898-2 mechanical properties standards. The ASTM and ASME fastener committees will be meeting in Denver, Colorado, May 13–15, 2019.

John Medcalf is Engineering and Business Lead for Peak Innovations Engineering and is NFDA's technical representative.

Communication between NFDA members and the NFDA technical standard representative (the "Representative") through email or otherwise is provided by NFDA as a courtesy to its members. NFDA provides no assurance as to the accuracy, completeness, or timeliness of any statement made by the Representative to the member or fastener technical standards organizations. Neither NFDA nor the Representative makes any representation as to whether any statement of the Representative is consistent or compliant with fastener technical standards. Neither NFDA nor the Representative shall be responsible for any loss or damage suffered by the member or any other person as the direct or indirect result of any statement made by the Representative.

John Medcalf was appointed as the NFDA technical standards representative to allow the NFDA membership not just visibility of standards activities, but also a voice in the process.

NFDA members are encouraged to express their comments or concerns relating to fastener standards. The only way to influence the process is to stay engaged and participate.

Members can:

- Inquire about changes in drafts noted in the quarterly reports
- Raise suggested revisions or technical updates to standards
- Ask general standards related questions
- Offer feedback to continue refinement of these articles

Please email your standards related comments, concerns or questions to John at standards@nfda-fastener.org

Visit us at Fastener Fair USA



This year the show will be at the Cobo Center in Detroit, Michigan, May 22-23. Fastener Fair USA combines a comprehensive display of industry innovation with highly relevant education and opportunities to connect with peers and industry experts.

Complimentary registration is available for NFDA members. Use promo code FF170 and be sure to visit us at booth #732!

Scholarships for Fastener Training Week

Twice each year NFDA awards a scholarship for Fastener Training Week, an advanced technical training program produced by the Fastener Training Institute®.

Applicants are evaluated based on the recommendation from their employer, personal achievements, work experience, and an essay. Identifying information is redacted, so the team evaluating the applications do not know the names or employers of those applying.

Fastener Training Week scholarships are a benefit for NFDA members only. The next deadline to apply for a scholarship is June 1. The application can be found at nfda-fastener.org/fastener-training-week-scholarship. Apply today!

For more information about Fastener Training Week, visit fastenertraining.org

MWFA/NFDA/PAC-WEST Joint Conference in San Diego





See more photos from the conference at facebook.com/nfdafastener

NEW / EXPANDED METRIC PRODUCT LINES

Visit us at the
National Industrial
Fastener & Mill
Supply Expo
Booth #1231

BBI components are manufactured to the highest quality standards, supported by our industry-leading customer service

- Metric Sockets
- Metric Cap Screws 8.8 / 10.9
- Metric Carriage
- Flange Bolts
- Metric Nuts
- Metric Washers
- Metric Machine Screws
- A2-A4 Stainless Steel
- Zinc CR3

RECENT ADDITIONS

- *DIN 125A Flat Washer 200HV Plain (BBI # 248)*
- *DIN 125A Flat Washer 140HV Zinc Yellow (BBI # 250)*
- *Hex Weld Nut DIN 929 Plain (BBI # 416)*
- *Hex Domed Acorn Nuts DIN 1587 Class 6 Zinc CR+3 (BBI # 417)*
- *Hex Nuts Class 8 DIN 934 Zinc Yellow (BBI # 522)*
- *Class 8 Hex Flange Locknut Metric Zinc CR+3 DIN 6927 (BBI # 523)*
- *DIN 127B Split Lock Washers Thru Hardened Plain (BBI # 744)*

"Service you know from the partner you trust"

Stocking a full line of
DIN and ISO standards
in Low Carbon, Alloy
and Stainless Steel



BRIGHTON-BEST INTERNATIONAL



www.brightonBEST.com • 1-800-275-0050



USA • Atlanta, GA • Boston, MA • Charlotte, NC • Chicago, IL • Cleveland, OH • Dallas, TX • Denver, CO • Detroit, MI • Houston, TX • Logan Township, NJ • Los Angeles, CA • Rogers, MN
• Miami, FL • Nashville, TN • Salt Lake City, UT • Portland, OR • San Francisco, CA • Sayreville, NJ • Seattle, WA • St. Louis, MO • Tampa, FL CANADA • Montreal, QC • Toronto, ONT • Vancouver, BC
BRAZIL • Sao Paulo AUSTRALIA • Brisbane, QLD • Melbourne, VIC • Perth, WA • Sydney, NSW NEW ZEALAND • Auckland UK • Cradley Heath, WMD TAIWAN • Tainan

BBI products and services offered exclusively through distribution ©2017 Brighton-Best International, Inc.

Proffered® VENDING SOLUTIONS



DID YOU KNOW ?

A recent industry publication reports that over 5,000* vending machines were signed the first quarter of 2017

* Industrial Distribution Daily, April 12, 2017



Talk to your Account Manager to set up an appointment to experience vending first hand

- Delivers the power of automated distribution by reducing supply cost, controlled product usage and state of the art technology
- High Quality Coil & Locker Machines
- Simple PIN or Card Swipe Login
- 365 Day Software Support
- Sell your service, sell your quality, sell vending



BRIGHTON-BEST INTERNATIONAL



www.brightonBEST.com • 1 - 8 0 0 - 2 7 5 - 0 0 5 0

USA • Atlanta, GA • Boston, MA • Charlotte, NC • Chicago, IL • Cleveland, OH • Dallas, TX • Denver, CO • Detroit, MI • Houston, TX • Logan Township, NJ • Los Angeles, CA • Maple Grove, MN • Miami, FL • Nashville, TN • Salt Lake City, UT • Portland, OR • San Francisco, CA • Sayreville, NJ • Seattle, WA • St. Louis, MO • Tampa, FL CANADA • Montreal, QC • Toronto, ONT • Vancouver, BC BRAZIL • Sao Paulo AUSTRALIA • Brisbane, QLD • Melbourne, VIC • Perth, WA • Sydney, NSW NEW ZEALAND • Auckland UK • Cradley Heath, WMD TAIWAN • Tainan

BBI products and services offered exclusively through distribution. ©2017 Brighton-Best International, Inc.



The Value of Partnering With Us



QUALITY

You receive only Rotor Clip brand products produced to the highest quality standards in the industry, guaranteed.



WARRANTY

Purchase with confidence, because all Rotor Clip products are manufacturer warranted with full lot traceability giving you peace of mind.



SUPPORT

We support you through all stages of the process. From Samples to Engineering Assistance, to Delivery and beyond. We are here for you!

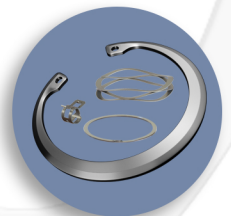

SELECTION

Rotor Clip offers one of the broadest product lines in the industry. We manufacture a full line of Tapered section-, Constant section-, and Spiral Retaining Rings, as well as a complete line of Wave Springs and Hose Clamps.



732-469-7333



sales@rotorclip.com

www.rotorclip.com



Full Industry Support

We provide high performance design solutions with **retaining rings**, **wave springs**, and **hose clamps** for all Manufacturing Industries, including Medical Devices, Automation, Robotics, Energy, Aerospace and Automotive. **Available in industry standards and custom configurations.**

Strong • Precise • Resistant • Traceable

Manufactured & Certified to: IATF 16949 • ISO 9001 • AS9100 • ISO 14001

Contact us for your solution
info@rotorclip.com

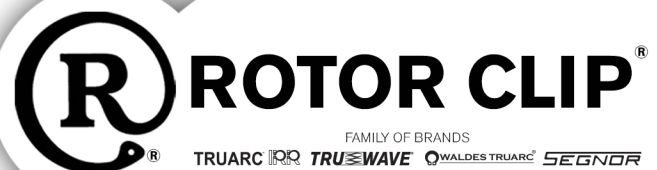

Designed for Quality

TRUARC TRUWAVE WALDES TRUARC SEGNOR

ADVANCE

COMPONENTS

in two minutes



Founded in **1972**.

A true Master Stocking Distributor, **FOCUSED** on selling to distributors and having relationships built on **TRUST**.



SECOND GENERATION family-owned, Certified Women-Owned Business.

Central location in the **DALLAS METROPLEX** ensures fast and efficient service.



FINANCIAL SECURITY with strong profits, cash reserves & exceptional credit.

Exceptional service, product knowledge and technical support from our **COMMITTED** sales team.



Manufacturers can develop their **CORE COMPETENCIES**, improve operational efficiency & profitability, and focus on manufacturing their products.

CUSTOMIZED SOLUTIONS that mitigate price volatility, improve cash flow & reduce transactional costs.



IN-STOCK and ready to ship products from top domestic manufacturers.

INVENTORY OPTIMIZATION that save time & money on warehouse costs.



Over **1000 CUSTOMERS** in U.S, Canada, Mexico, Europe, South America, Africa and Asia.



ADVANCE

COMPONENTS

ARaymond[®]
MORE THAN FASTENING
TINNERMAN



J Johnson & Hoffman
precision metal stamping



HEYCO
PRODUCTS, INC.



AVK



VFS
VOGELSANG FASTENER SOLUTIONS

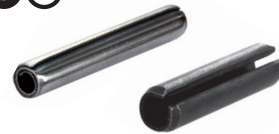

E
ESSENTRA

M
micro plastics, inc.



Removal
Incorporated



DAVIES
MOLDING



PARKER
FASTENERS



FAST CUSTOM TURNED PARTS

24/7 Manufacturing | Print To Part in 7 Days | Made in the USA

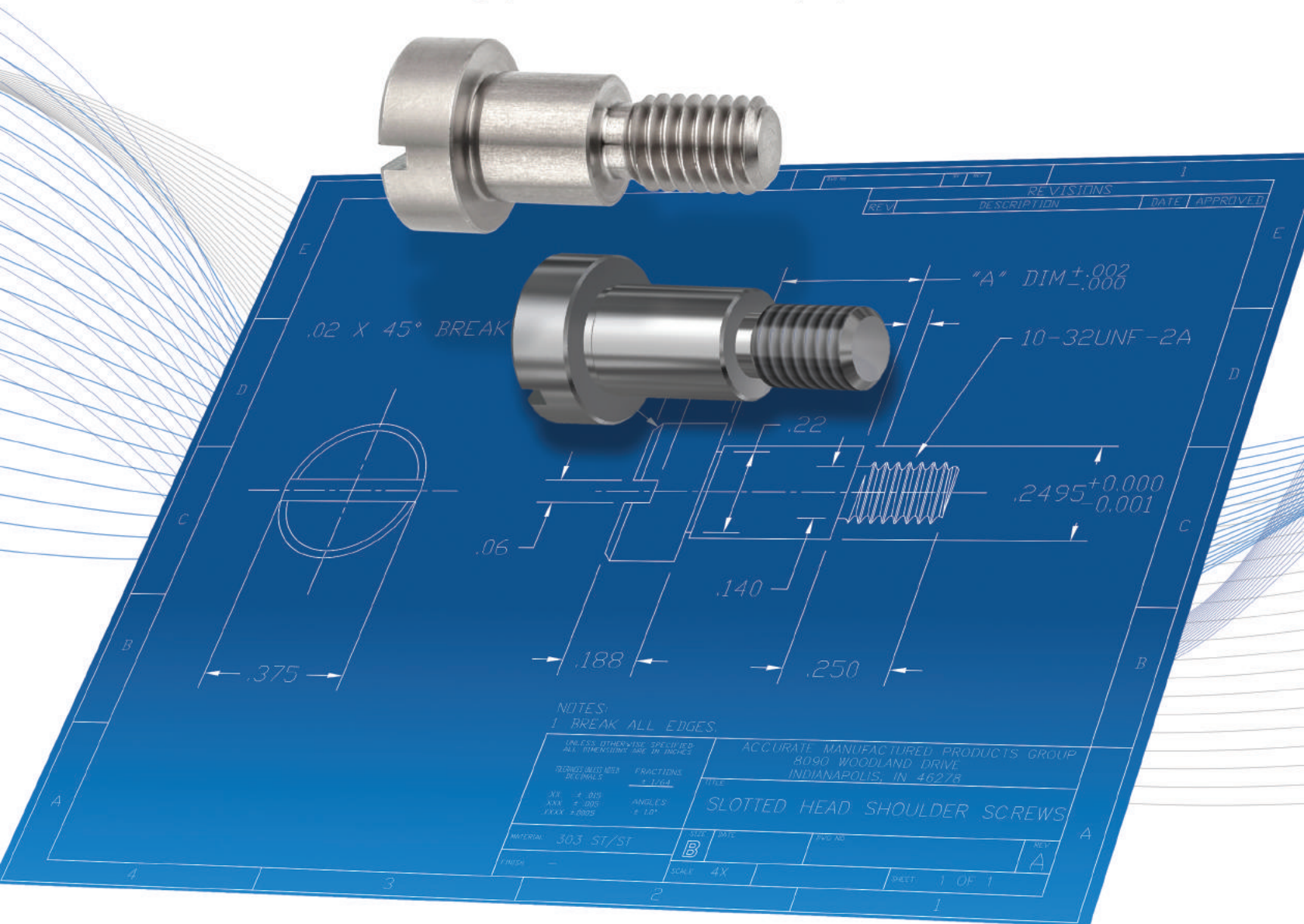

Custom parts to your spec, print, or design are manufactured on our state-of-the-art CNC Swiss Lathes, with short lead times and from domestic raw materials.

Learn more at ampg.com/engineered



Beautiful Parts, Right Now

Visit us online and search our catalog at ampg.com.

8090 Woodland Drive
Indianapolis, IN 46278

p: 317.472.9000
f: 317.472.9010

AMPG

Beautiful Parts, Right Now New Parts All The Time

316 High 5 SS™ Material Line

The corrosion resistance of 316 SS
& the strength of Grade 5 Steel

Available for Shoulder Screws, Socket Screws,
Hex Head Cap Screws, Washers & Nuts



Insert (Allen) Nuts

Inch from 4-40 to 1-14 &
Metric from M3 to M24

New in 18-8 SS &
Black Oxide Steel



Six Lobe Flat Head Socket Screws

New in A286 SS



Fits directly onto the
wrench, for tight spaces

Square Drive Socket Head Screws

Designed for 1/4" & 3/8"
Drive Socket Wrenches

New in 18-8 SS

Fast, Custom Turned Parts | Print to Part in 7 Days

CABLE TIES

UNLIMITED

YOUR ONE-STOP SHOP FOR CABLE TIES & SUPPLIES

CABLE TIES UNLIMITED is a leader in the distribution of cable ties and related accessories, terminals, connectors and other wire management products for the industrial and electrical markets. Since 2001, **CABLE TIES UNLIMITED** has been providing industry leading products and quality service, domestically and internationally. **CABLE TIES UNLIMITED** is a recognized leader in the industry and has become the only one-stop shop for all of the leading brands of cable ties and related products and accessories.

**IF WE
DON'T HAVE
IT, WE'LL
FIND IT!**

Thomas&Betts **Catamount** **VELCRO** **PANDUIT** **molex** **HellermannTyton**



**NYLON
CABLE TIES**



**MOUNTING
BASES**



**ELECTRICAL
TAPE**



**STAINLESS STEEL
CABLE TIES**



**VELCRO BRAND
HOOK & LOOP**



**ELECTRICAL
TERMINALS**



**SPECIALTY MATERIAL
CABLE TIES**



**WIRE DUCT
& SLEEVING**



**WIRE
CONNECTORS**



**SPECIALTY USE
CABLE TIES**



**SOLAR TIES
& CLIPS**



**HEAT SHRINK
TUBING**



**CABLE TIE
TOOLS**



**ASSORTMENT
PACKS**



**WIRE MARKING
SYSTEMS**

WE OFFER CUSTOM IMPRINTED CABLE TIES TOO!

CABLE TIES UNLIMITED

420 Pearl Rd, Brunswick, OH 44212

Toll-Free: 866-455-TIES (866-455-8437)

Tel: 330-558-0600 | Fax: 330-558-0661

Email: info@cabletiesunlimited.com

For more information visit

www.CTUPro.com

CABLE TIES

UNLIMITED

PRODUCTS

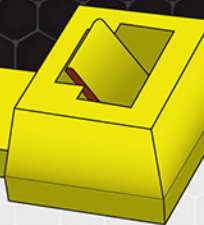

NYLON CABLE TIES

Natural Nylon
UV Black Nylon
Colored Cable Ties (13 Colors)
Miniature (18lb)
Intermediate (40lb)
Standard (50lb)
Light Heavy Duty (120lb)
Heavy Duty (175lb)
Extra Heavy Duty (250lb)

STAINLESS STEEL CABLE TIES

Light Duty (150lb)
Heavy Duty (300lb)
Black Polyester Coated (150lb/300lb)
Red Polyester Coated (150lb)
Polyester Coated Releasable (300lb)
PPA Coated
Ladder Ties

THOMAS & BETTS

Ty-Rap® Cable Ties
Ty-Rap® Color Cable Ties
Ty-Rap® Mounting Head Ties
Ty-Rap® Push-Mount Ties
Ty-Rap® Halar Ties
Ty-Rap® Tefzel Ties
Ty-Rap® Identification Ties
Ty-Rap® Flame Retardant Ties
Ty-Rap® Heat Stabilized Ties
Ty-Rap® Color Cable Ties
Catamount® Cable Ties

PANDUIT

Dome Top® Barb Ty
Pan-Ty®
Pan-Steel®
Terminals

HELLERMANN TYTON

Cable Ties
Wiring Duct
Clamping
Identification Systems
HelaCon Wire Connectors

SPECIALTY USE TIES

Color Cable Ties (13 Colors)
Releasable Ties
Push-Mount Cable Ties
Fir-Tree Cable Ties
Screw-Mount Cable Ties
Beaded Cable Ties
Marker ID/Flag Ties
Ladder Ties
EZ-Off Tote Ties
Double Loop Ties
Ski Ties
Solar Ties
Low Profile Ties
Hand-Cuff Ties
Custom Imprinted Cable Ties
Consecutively Numbered Ties
Any-length Cable Ties
Shoe/Stop Ties
Loop Lock Retail Fasteners
Assortment Tubes

SPECIAL MATERIAL TIES

Plenum Rated (Halar Fluoropolymer)
Tefzel (Fluoropolymer)
Extreme Temperature
Metal Impregnated Nylon Metal Detectable
Metal Impregnated Polypropylene Metal Detectable
Heat Stabilized
PEEK (Polyetheretherketone)

SOLAR PRODUCTS

UV Stabilized Solar Ties
Impact Modified Heat/UV Stabilized Solar Ties
Nylon 11 Solar Ties
Nylon 12 Solar Ties
Polyacetal Solar Ties
Stainless Steel Solar Cable Ties
Edge Clips
Fir-Tree Solar Mount Ties
C-Clip Fir Tree Mounts
C Clips
UV Stabilized Mounting Base/Special Adhesive

CABLE MOUNTS/CABLE CLAMPS

Adhesive Mounts
Saddle/Screw Mounts
Nylon Cable Clamps

CABLE TIE TOOLS/CRIMP TOOLS

Tension Tools/Crimping Tools
Nylon and Special Material Tie Tools
Stainless Steel Tie Tools
Crimping Tools
Removal Tools
Velcro® Brand Cable Management
One Wrap® Tape
One Wrap® Straps

HEAT SHRINK TUBING

3:1 Polyolefin Dual Wall/Adhesive Lined
2:1 Polyolefin
Thin Wall Polyolefin (Low Shrink)
Heat Guns

WIRE MARKING SYSTEMS

Slide-on/Clip-on Wire Markers
Wire Marker Books
Cable Marking Strips
Stainless Steel Marking Strips
Thermal Transfer Printers
Printable PVC Tubing
Printable Heat Shrink Tubing

MOLEX

Terminals
Connectors

WIRE CONNECTORS

Standard
Winged
Grounder
Waterproof
High Temperature
Push-In Connectors

TERMINALS

Bullet Connectors
Butt Connectors
Closed End Connectors
Eyelets
Hook Terminals
Parallel Connectors
Quick Disconnects
Ring Terminals
Spade Terminals
Terminal Kits
Terminal Strips
X & Y Connectors

CABLE SLEEVING

Wire Loom
Braided Sleaving
Spiral Wrap



For more information visit
www.CTUPro.com

To place an order call us toll-free
866-455-TIES (866-455-8437)

Capital Marketing™

SALES, MARKETING & CONSULTING FROM A PREMIER AGENCY

SERVING NORTH CAROLINA, SOUTH CAROLINA & VIRGINIA



**Capital Marketing is headed by
Robbie Gilchrist, a 48-year
veteran of the fastener business**

Robbie has the distinction of being
NFDA's Fastener Professional of the Year
and is a Fastener Hall of Fame member

**CALL ROBBIE TODAY TO DISCUSS HOW YOU WILL BENEFIT
FROM HIS MANAGEMENT, SALES AND M&A EXPERIENCE**

tel: 336-906-9401 email: rgilchr485@aol.com



Earnest

How can we help you **today?**

We make **custom fasteners, easy!**

Multiple vendors, P.O.'s, and shipping costs. Stacks of receipts and invoices. Missed deadlines, missing parts, and missing quality. **Getting parts customized shouldn't be this hard.**

Earnest Machine makes it easy. We drill, plate, and rework standard parts from our inventory or your's. Create custom hex screws from blanks and manufacture parts to-print. Managing the process for you, saving you time, money, and delivering custom and secondary services on one P.O.

On-time. Everytime.



Learn more at EarnestMachine.com/custom
or call **800.327.6378.**



GLOBAL CAPABILITY

MACHINING SERVICE	U.S.	U.K.
Rework of existing fasteners	Yes	Yes
Quick Custom Hex Heads from Blanks	Yes	Yes
To-Print Services	Yes	Yes

SECONDARY SERVICES	U.S.	U.K.
Coating & Plating	Yes	Yes
Cut/Thread/Chamfer	Yes	Yes
Drilling (High volume & Low volume)	Yes	Yes
Broaching	Yes	Yes
Dog Point	Yes	Yes
Deep Drilling (Length of bolt)	Yes	Yes
Boring	Yes	Yes
Engineering Consultation	Yes	Yes
Facing	Yes	Yes
Grinding	Yes	Yes
Heat Treating	Yes	Yes
Keyways	Yes	No
OD Grinding	Yes	Yes
ID Grinding	Yes	Yes
Small Diameter Drilling	Yes	Yes
Stamping	Yes	Yes
Thread Rolling	Yes	Yes
Type 23	Yes	No
Welding	Yes	No

**Short lead times.
Low quantity runs.
High volume welcome.
On-time
Everytime.**



For inquiries in the United States call **800.327.6378**



For inquiries in England & Europe call **+44 (0) 1902 711041**

COMMON QUICK CUSTOM CONFIGURATIONS

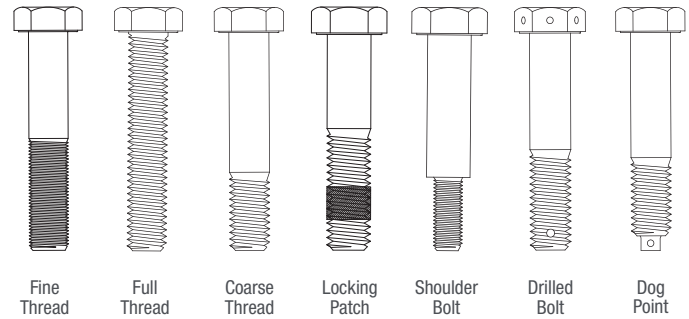

HEX HEAD CAP SCREW BLANK STOCK

DIAMETER	PRODUCT	LENGTH	GRADE	FINISH
0.875"	Hex Head Cap Screw Blank	up to 20"	8	Plain
1.00"	Hex Head Cap Screw Blank	up to 15"	8	Plain
1.25"	Hex Head Cap Screw Blank	up to 15"	8	Plain
1.50"	Hex Head Cap Screw Blank	up to 15"	8	Plain
1.75"	Hex Head Cap Screw Blank	up to 10"	8	Plain
2.00"	Hex Head Cap Screw Blank	up to 20"	8	Plain

DIAMETER	PRODUCT	LENGTH	GRADE	FINISH
M30	Hex Head Cap Screw Blank	up to 425m	10.9	Plain
M36	Hex Head Cap Screw Blank	up to 425m	10.9	Plain
M42	Hex Head Cap Screw Blank	up to 425m	10.9	Plain

#7 HEAD PLOW BOLT BLANK STOCK

DIAMETER	PRODUCT	LENGTH	GRADE	FINISH
.625"	#7 Head Plow Bolt Blank	up to 10"	8	Plain
.750"	#7 Head Plow Bolt Blank	up to 17"	8	Plain
.875"	#7 Head Plow Bolt Blank	up to 17"	8	Plain
1.00"	#7 Head Plow Bolt Blank	up to 17"	8	Plain
1.25"	#7 Head Plow Bolt Blank	up to 8"	8	Plain
1.50"	#7 Head Plow Bolt Blank	up to 12"	8	Plain

SQUARE HEAD BLANK STOCK

DIAMETER	PRODUCT	LENGTH	GRADE	FINISH
.625"	Square Head Bolt Blank	up to 12"	5	Plain
.875"	Square Head Bolt Blank	up to 15"	5	Plain
1.00"	Square Head Bolt Blank	up to 6"	5	Plain
1.00"	Square Head Bolt Blank	up to 20"	8	Plain
1.125"	Square Head Bolt Blank	up to 15"	8	Plain
1.25"	Square Head Bolt Blank	up to 22"	5	Plain
1.50"	Square Head Bolt Blank	up to 20"	5	Plain



***DISTRIBUTOR FOCUSED.
QUALITY DRIVEN.
TIME TESTED.***



***WWW.ELGINFASTENERS.COM
FASTENER HOTLINE: 812.689.8990***



7 BRANDS 1 PURPOSE

TO SUPPORT OUR DISTRIBUTORS WITH THE WIDEST
PRODUCT OFFERING, BEST DELIVERY AND HIGHEST
QUALITY FASTENER SOLUTIONS AVAILABLE.



TRUSTED
BY DISTRIBUTORS LARGE AND SMALL
FOR DELIVERING THE HIGHEST QUALITY
SPECIALTY FASTENERS



MORE THAN
1.3 BILLION
PARTS SHIPPED ANNUALLY



SPECIALTY FASTENERS AND WIRE FORMS
MADE TO PRINT WITH IN-HOUSE ENGINEERING
SUPPORT AND DESIGN HELP

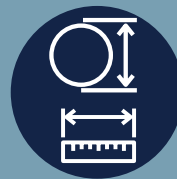

**BOLTS, SCREWS, RODS,
STUDS AND NUTS**

- FROM 3/16" TO 96" IN LENGTH
- 1/4" TO 1 1/4" IN DIAMETER
- NUTS FROM 1/4" TO 7/8"
- METRIC OPTIONS ASLO AVAILABLE

WIRE FORMS

- CUSTOM CNC CAPABILITIES
- 3/32" TO 1" IN DIAMETER
- 1/2" TO 144" IN LENGTH



WIRE FORMS



LONG BOLTS AND RODS



NUTS



**BOLTS, SCREWS, RIVETS
AND STUDS**



WWW.ELGINFASTENERS.COM
FASTENER HOTLINE: 812.689.8990





HARD-TO-FIND METRIC FASTENERS... DELIVERED!®



A4-80
Stainless Steel
Fasteners



HEX HEAD
Cap Screws



**SOCKET
HEAD**
Cap Screws

NUTS



WASHERS



SCREWS



BOLTS



PINS



MISCELLANEOUS



MAY 22-23
DETROIT MI



EUROLINK
FASTENER SUPPLY SERVICE

ON TOUR

**INTERNATIONAL
FASTENER EXPO**
SEPT. 17-19
LAS VEGAS NV

EUROLINK_{sea}
Economical & predictable
delivery for one-time and
standing orders on hard-to-find
metric fasteners.



EUROLINK_{air}
The fastest delivery for hard-to-find
metric fasteners—weekly air freights
for those times when you've really
gotta' have it!

toll-free (866) 787-7594

phone: (864) 801-0505 | www.EurolinkFSS.com | sales@eurolinkfss.com



HARD-TO-FIND
METRIC FASTENERS...DELIVERED!®

toll-free (866) 787-7594

phone: (864) 801-0505 | www.EurolinkFSS.com | sales@eurolinkfss.com

EXCLUSIVE FOR NFDA MEMBERS!

REGISTER FOR FREE WITH CODE NFDA19

Fastener Fair USA is a proud partner of NFDA! The mission of Fastener Fair USA aligns well with the mission of NFDA: to help you thrive in a global marketplace through advancing interests in the fastener industry, to encourage relationships between you and the full fastener supply chain, and to promote the improvement of quality in and the expansion of markets for fasteners.

In addition to being able to connect with over 250 exhibitors offering the solutions you need, you'll also benefit from our Distributor Track sessions and be able to network with the industry at our Welcome Party, held May 22 at 5 pm.

What are you waiting for? Register for FREE with code **NFDA19** at fastenerfair.com/usa.

SHOW RATES

EXHIBIT HALL PASS (through April 26)	FREE with code NFDA19
EXHIBIT HALL PASS (after April 26 and on-site)	FREE with code NFDA19
FASTENING 101 (held Tuesday, May 21 before show opens)	\$399.00 USD
WELCOME RECEPTION AT GM RENAISSANCE CENTER (includes drinks and appetizers)	\$30.00 USD



JOINING THE INDUSTRY WITH EDUCATION

At Fastener Fair USA, equipping you with the tools and training you need to do your job is key. Take advantage of multiple learning opportunities throughout the event to sharpen your expertise, strengthen your network, and stay up-to-date on the latest industry advancements.

NEW THIS YEAR

Fastener Fair USA will feature more free education sessions to better serve the multitude of functions within the fastener industry. The **DistributorTracks** sessions will feature experts in the industry with best business practices, and the **TechTalks** sessions will feature the latest in technical processes and technology. All sessions will be located on the show floor and are included in your exhibit hall pass.

Check out the sessions and head to fastenerfair.com/usa to register today!



MAY 22-23, 2019
COBO CENTER
DETROIT, MICHIGAN, USA

SCHEDULE AT A GLANCE

TUESDAY, MAY 21	TIME
REGISTRATION OPENS	8:00am
FTI SEMINAR-FASTENING 101	8:30am – 4:30pm
WEDNESDAY, MAY 22	
EXHIBIT HALL OPEN	10:00am – 5:00pm
KEYNOTE SESSION	9:00am – 9:50pm
THEATER PRESENTATIONS	10:00am – 5:00pm
WELCOME PARTY AT GM RENAISSANCE CENTER	5:00pm – 8:00pm
THURSDAY, MAY 23	
EXHIBIT HALL OPEN	10:00am – 3:00pm
THEATER PRESENTATIONS	10:00am – 3:00pm

Subject to change. Please check fastenerfair.com/usa for the most current schedule.

REGISTER NOW at fastenerfair.com/usa

KEYNOTE SESSION

TRANSFORM. IGNITE. DISRUPT.

Tuesday, May 22, 9:00am - 9:50am

Steve Blue, Miller Ingenuity

It is possible for rust-belt companies to achieve superior profits, enter new markets, and repel offshore competition. This keynote provides a blueprint for senior executives that want to revitalize, reinvent, and rejuvenate their companies. Explore ways to unleash a blizzard of new highmargin products that will delight your customers and destroy your competition.

DISTRIBUTOR TRACKS

SEVEN REASONS WHY YOUR COMPANY NEEDS SUSTAINABILITY TO SURVIVE

Gail Friedberg, Zago Manufacturing

Over the past decade sustainability has moved from the fringes of the business world to a top priority. Adopting sustainable business practices not only makes your company more appealing to customers, it makes it a more attractive workplace. Learn why you need to sustainability to survive and thrive in the today's hyper-competitive marketplace.

FALLING DOWN

PJ McCaughn, Innovative Components, Inc.

Let's face it, sometimes bad things happen to good people and all of us have experienced adversity in our lives: Being let go from our job, getting passed up for a promotion, financial instability – the list goes on and on. In this presentation, we will



discuss tips, techniques and strategies to cope with these tough situations, put our train back on the tracks, and come through the other side intact.

EXECUTING AT THE SPEED OF CHANGE

Mike White, Brighton Best International

The demands placed on the modern distributor are undergoing a tectonic shift. No industry is excluded from the intense pressure to deliver in response to the demands of the customer. Engineering a new solution in this environment is paramount to success and business sustainability. The focus of this session will be on unpacking this new environment and setting attendees on a path to win through a commitment to strategic execution.

REGISTER TODAY WITH CODE NFDA19!

TECH TALKS

THE KEY TO INDUSTRY 4.0 SUCCESS: WHY MOST PROJECTS FAIL AND HOW TO LEARN FROM THEIR MISTAKES

Graham Immerman, MachineMetrics

Of the many manufacturers that are in pursuit of digitization, a large number of these projects are unlikely to succeed and this failure rate has led to a greater hesitation for manufacturers to embark on their digital transformation journeys. So, what's the key to digitalization success? Attend this presentation to find out.

RISK MANAGEMENT

Carmen Vertullo, CarVer Consulting and Rob LaPoint, AIM Testing Laboratory

What steps need to be taken to ensure your risk management plan is ready? During this presentation, Carmen will uncover the ways successful businesses use quality management to identify, assess, assign and strategize for risk management.

FUNDAMENTALS OF THREADED FASTENERS

Dr. Sayed Nassar, Fastening and Joining Research Institute and Oakland University

This presentation highlights the key aspects necessary for ensuring the safety, quality, and reliability of threaded fastener systems. Beyond corrosion protection function of fastener coating, learn more about other significant effects of coating and friction in threaded fasteners.

Sessions as of March 28. Visit fastenerfair.com/usa for the full session list and schedule.



CONSISTENT GLOBAL QUALITY ASSURED IN AN OEM WORLD

Lammert DeBoer, ZinKlad, DecoKlad & XMAPP

As automotive OEM performance requirements continue to increase, increased challenges are presented to the supply chain to provide consistent quality parts. This session will discuss a unique new quality assurance program that tackles the challenges for high-performance automotive coatings throughout the applicator network.

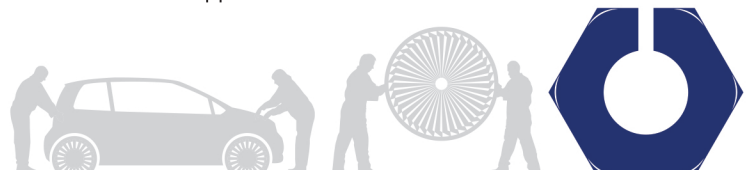

REGISTER NOW at fastenerfair.com/usa



**REGISTER
TODAY!**

Visit bit.ly/IFE_B

INTERNATIONAL FASTENER EXPO

**THE LARGEST AND MOST ESTABLISHED FASTENER SHOW IN NORTH AMERICA
CONNECTING DISTRIBUTORS WITH SUPPLIERS SINCE 1981**

MEET OVER 850+ SUPPLIERS



72% said IFE is the most important Fastener event they attend



98% consider IFE a must attend event



Comprehensive conference programs



Opportunity to build new relationships, network with industry leaders and business partners, and find new products

September 17-19, 2019

Mandalay Bay Convention Center · Bayside D-E, Las Vegas, NV, USA · Visit Us Online: www.FastenerShows.com

our **fresh** new **website** is **now live!**



- more **information**
- extensive **products**
- easy to **navigate**
- useful **resources**
- integrated **search**
- fast and **efficient**



visit our new and improved website at www.semsandspecials.com