

## NFDA CALENDAR

### Annual Meeting & Executive Sales Planning Sessions®

For your health and safety, NFDA will postpone our June 23-25 Executive Sales Planning Sessions® to a later date.

### Visit us at Fastener Fair USA



Stop by the NFDA booth at the Charlotte Convention Center in Charlotte, North Carolina, July 13 - 15, 2020.



## PRESIDENT'S MESSAGE

By Doug Ruggles

## WELCOME NEW NFDA MEMBERS

**Brown & Brown of Florida, Inc.**  
[bbinsurance.com](http://bbinsurance.com)

**DB Fasteners**  
[dbfasteners.cn](http://dbfasteners.cn)

**Delta Secondary LLC**  
[deltasecondary.com](http://deltasecondary.com)

**Goebel Fasteners, Inc.**  
[goebelfasteners.com](http://goebelfasteners.com)

If you prefer to receive this newsletter electronically only, please email:  
[amy@nfda-fastener.org](mailto:amy@nfda-fastener.org)

What do a rock, a flea, and a plate have in common with business? Hint: they're all associated with surprise and danger. Any ideas? The rock is the dinosaur-killing asteroid that slammed into what is now the Gulf of Mexico 65 million years ago. The flea contributed to wiping out half of Europe during the Dark Ages. The plate was the tectonic kind that slipped on Boxing Day 2004, creating the south Asia, 9.3 megathrust earthquake and tsunami. All Black Swan events as they call them. Well, we can add COVID-19 to this list.

There are many adjectives we can use to describe this global event: unprecedented, unbelievable, extraordinary, never in my lifetime, and disruptive to name a few. It is definitely a Black Swan. As one of my friends wrote in his newspaper column lately, "So, going forward, can we stipulate that a Black Swan event is less about something we've never imagined and more about being prepared for a disruption at least somewhat out of our control?" It's not a matter of **if** but **when**, as well as how well have you planned for the disasters. Could we have planned for the entire world to shut down? No. But like in 2001 and 2008, big events do happen, and as leaders of our respective businesses it's our job to plan for something to happen, then hope it never does.

As of this writing, early April, we are all in a "shelter in place" order. A new normal has taken place of working from home. However, there are signs of the curve flattening. I've read many scenarios of what recovery is going to look like: V shaped, U shaped, or L shaped. I hope and pray for everyone around the globe that we can defeat this virus, and our ingenuity and capitalistic society here in the US can develop a vaccine sooner than later. I heard a commentator on the radio say we should

have long-term confidence in all of us getting back together, because throughout history humans have gathered, and we will gather again!

So, when we do gather again for our next industry event, what's the thing you must do as a leader? You must talk to each other, share best practices, ask open questions about how you planned for disasters, how you managed your team, who you sought for information, where you found the best information, etc. All great questions and only answered if you are involved in associations like the NFDA. Don't let this disaster go to waste; use it to make changes in your business, plan for the next one, and manage it with information you get from each other. The job of the NFDA is to facilitate; it's your job to participate, and that is how to prepare for the next Black Swan.

Remember the membership incentive program. NFDA is in the membership business, and we need you bringing in new members. If you suggest a prospective NFDA member and they join, your dues will be credited \$1,000!

I also encourage your feedback, suggestions, ideas and / or comments directly to me at [doug@martinsupply.com](mailto:doug@martinsupply.com) or you can reach me directly at 256-248-0412.



## MARKET YOUR BUSINESS THROUGH NFDA

Interested in having an insert about your company in the next issue of NFDA Today? Contact Amy Nijjar to make the arrangements: [amy@nfda-fastener.org](mailto:amy@nfda-fastener.org) or 562-799-5519. You also can view information on our website. Click on Advertising in the menu.

**ASSOCIATE CHAIR’S MESSAGE** By Kelly Charles



It is hard to believe that the Long Beach Conference and Tabletop Show was just last month! It was great to see everyone, as usual; my favorite part was listening to Dr. Chris Thornburg update us on the economy. What is happening today is very different than what we were anticipating in early March.

As the COVID-19 situation has shown us, the only constant is change. Allow the NFDA to help you navigate these uncertain times. We have an online COVID-19 forum, where members can

ask questions, as well as share tips on what has been working for their companies.

Check the website for information, tools, and webinars that can help us all to get through this. Look for periodic emails letting you know what the NFDA can offer you.

Stay safe and stay distant but connected through our organization, Until we can be together again, in person.

- Kelly Charles

**NFDA FASTENER STANDARDS ACTIVITY UPDATE – Q1 2020**

By John Medcalf

As I write this column, I’m sure more attention is on the NIOSH N95 standard for respirators than fastener standards. And indeed, measures taken to slow the spread of COVID-19 have caused the cancellation of all in-person fastener standards meetings scheduled to take place in May and June. However most, if not all, fastener suppliers have been deemed essential businesses in their support of critical infrastructure. As such, the industry must find a way to stay productive, with standards committees investigating options for teleconferencing much the same way many NFDA members have found a way to support their companies remotely.

So, while I can’t report how or when the next meetings may take place, I can still provide a few updates on projects currently in progress:

**ISO**

Meetings were held in Paris in February, with discussions centering around the ISO 2702 case hardened tapping screw specification, ISO 4042 electroplating standard, and ISO 898-1 and -2 specifications on externally and internally threaded fastener mechanical properties. Also still under review are the 16047 and 15330 specifications on torque-clamp force testing and hydrogen embrittlement testing.

**ASTM**

The allowance for galvanizing grade A490 bolts is being considered within ASTM F3125. ASTM F606 on test

methods is being reviewed for the addition of Charpy testing and updates to the hydrogen embrittlement test method in conjunction with ISO 15330. ASTM F1941 on electroplating is being reviewed for a comprehensive update. Some final updates to the combined zinc flake coating specification are being considered, and once approved it will be released as ASTM F3393.

**SAE**

SAE J429, the ubiquitous material and mechanical property standard for externally threaded fasteners is being reviewed for revision.

*Communication between NFDA members and the NFDA technical standard representative (the “Representative”) through email or otherwise is provided by NFDA as a courtesy to its members. NFDA provides no assurance as to the accuracy, completeness, or timeliness of any statement made by the Representative to the member or fastener technical standards organizations. Neither NFDA nor the Representative makes any representation as to whether any statement of the Representative is consistent or compliant with fastener technical standards. Neither NFDA nor the Representative shall be responsible for any loss or damage suffered by the member or any other person as the direct or indirect result of any statement made by the representative.*

Please email your standards related comments, concerns or questions to John at [standards@nfda-fastener.org](mailto:standards@nfda-fastener.org)

John Medcalf’s appointment as the NFDA technical standards representative allows the NFDA membership not just visibility of standards activities, but also a voice in the process.

NFDA members are encouraged to express their comments or concerns relating to fastener standards. The only way to influence the process is to stay engaged and participate.

**MEMBERS CAN:**

- **Inquire about changes to drafts noted in quarterly reports**
- **Raise suggested revisions or technical updates to standards**
- **Ask general standards related questions**
- **Offer feedback to continue refinement of these articles**



## SCHOLARSHIPS FOR FASTENER TRAINING WEEK

Twice each year NFDA awards a scholarship for Fastener Training Week, an advanced technical training program produced by the Fastener Training Institute®.

Applicants are evaluated based on the recommendation from their employer, personal achievements, work experience, and an essay. Identifying information is redacted, so the team evaluating the applications do not know the names or employers of those applying.

Fastener Training Week scholarships are a benefit for NFDA members only. The next deadline to apply for a scholarship is June 1. The application can be found at [nfda-fastener.org/fastener-training-week-scholarship](http://nfda-fastener.org/fastener-training-week-scholarship). Apply today!

For more information about Fastener Training Week, visit [fastenertraining.org](http://fastenertraining.org)

## TRAINING OPPORTUNITIES

The Fastener Training Institute® offers the following opportunities to increase your fastener knowledge:

- **MAY 15** Webinar: Understanding ASME B18.6.3 – Machine Screws & Tapping Screws
- **JUNE 19** Webinar: Non-Threaded Fasteners: Rivets, Pins, Retaining Rings, Keys, Keyways and Washers
- **JULY 17** Webinar: Fastener Finishes & K Factor Determination - When Tight is Right

NFDA members receive discounted registration on all FTI classroom seminars. For more information and a list of all FTI events visit [fastenertraining.org](http://fastenertraining.org)

## DON NOWAK AWARDED NFDA'S 2020 FASTENER PROFESSIONAL OF THE YEAR AWARD



Fasteners (Holtsville, New York) said, "Don has been a contributor to the fastener industry and its associations for many years. His career has been filled with a high standard of ethics and integrity, and he has led a company that has grown in revenue and stature over the years. Don has been a mentor to many (including myself) and is willing and able to share his sound reasoning and good business sense when asked."

The National Fastener Distributors Association is pleased to announce the 2020 recipient of its Fastener Professional of the Year award is Don Nowak of Falcon Fastening Solutions (Charlotte, North Carolina).

The Fastener Professional of the Year award was created by NFDA to honor individuals and companies that make a substantial positive impact on people's lives. The inaugural award in 2017 was presented to Robbie Gilchrist of Capital Marketing (High Point, North Carolina). In 2018 Jim Ruetz of AIS (Franksville, Wisconsin) was honored and in 2019 Kevin Queenin of Specialty Bolt & Screw, Inc. (Agawam, Massachusetts) received the award.

In his nomination of Don to receive this award, Mark Shannon of Tower

Don began his fastener industry career at Kar Products (Des Plaines, Illinois) from 1970 to 1987, followed by a ten-year stint with Hoyt Fastener (Niles, Illinois) as president and chief operating officer.

In 1997 Don joined Falcon Metal Corporation (Charlotte, North Carolina). He was brought on board as a minority partner by Bruce Roberts, Falcon's founder. His charge was to develop a marketing/sales strategy to grow the business, and he has grown the company's revenues by 500%.

Don purchased Falcon when Bruce retired in 2008. The next year Falcon purchased the assets of C & M Industrial Solutions (Louisville, Kentucky) to expand the company's geographic focus. Falcon now has five facilities

(three are customer specific), including the headquarters in Charlotte, North Carolina.

In 2014 the company's name changed to Falcon Fastening Solutions. In 2018 a generational transfer of ownership to Don's daughter Carrie Cespedes and her husband Giovanni took place. Don remains as a part-time consultant.

Don served as a Board member and past president of the Chicago Bolt, Nut and Screw Association (now the Mid-West Fastener Association). He also served on the NFDA Board of Directors and the Southeastern Fastener Association Board. Don retired last year from the Fastener Advisory Board, a peer group he started with other fastener industry leaders in 1988.

Don has been married 48 years to his wife, Joan. He enjoys boating, racquetball, keeping in shape, and being a vocal spectator for his granddaughters' volleyball programs.

Don will be presented his award at the next NFDA event.

Nominations for the next Fastener Professional of the Year award will be open in January 2021.



### 2020 NFDA / PAC-WEST JOINT CONFERENCE

Long Beach, California

See more photos from the conference at: [facebook.com/nfdafastener](https://facebook.com/nfdafastener)

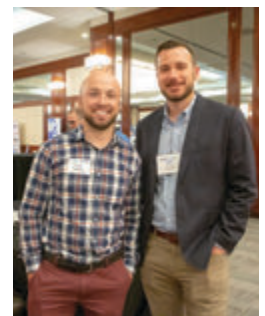

3020 Old Ranch Parkway Suite 300  
Seal Beach CA 90740  
562-799-5519  
[www.nfda-fastener.org](http://www.nfda-fastener.org)

**VICKIE LESTER**  
Executive Vice President  
[vl Lester@nfda-fastener.org](mailto:vl Lester@nfda-fastener.org)

# METRIC STAINLESS

A2-70  
A4-70  
A4-80

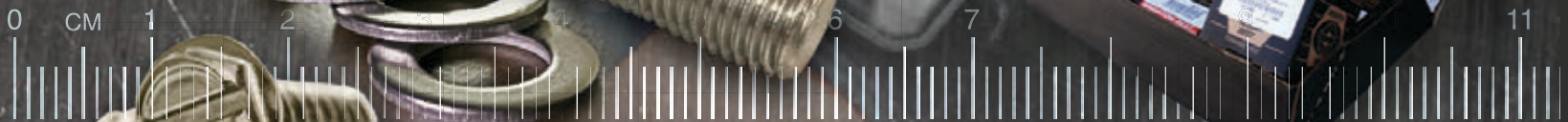
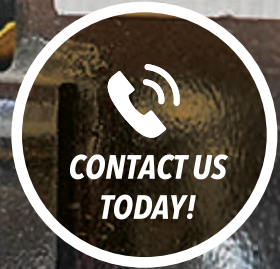

**MTRs**  
AVAILABLE

- Socket Screws
- Dowel Pins
- Hex Cap Screws
- Lock Nuts
- Washers
- Threaded Rod
- Screws



**BRIGHTON-BEST  
INTERNATIONAL**



www.brighton**BEST**.com • 1 - 8 0 0 - 2 7 5 - 0 0 5 0     

® All products and services offered exclusively through distribution of Brighton Best International, Inc.

# FLANGED CAPACITOR DISCHARGE (CD) STUDS

AVAILABLE  
NOW

MADE IN  
U S A

## Mild Steel, Copper Plated

- BBI# V20
- Diameters: 6-32 through 1/4"
- Lengths: 3/8 through 1-1/2"

## Stainless Steel

- BBI# V21
- Diameters 6-32 through 5/16"
- Lengths: 3/8 through 1-1/2"

## Aluminum

- BBI# V22
- Diameters 10-24 through 1/4"
- Lengths: 1/2 through 2"

- Material certifications, C of C's available. PPAP's available on special orders
- Other sizes, styles, and materials available by special order
- Available throughout BBI network



## ALSO STOCKING

### *Metric Hex Weld Nuts*

- High/Low Pilots
- 3 or 6 Projections

### *Metric Spot Weld Nuts*

- 5 variations



**BRIGHTON-BEST  
INTERNATIONAL**

FOUNDED 1925®

www.brightonBEST.com • 1 - 8 0 0 - 2 7 5 - 0 0 5 0



## TRUSTED PARTNERSHIP FOR 35 YEARS

Advance Components is an authorized master stocking distributor of AVK Industrial blind installed threaded inserts & installation tools, and a certified AVK tool repair station. For 35 years Advance has provided the industrial market with the largest variety of in-stock, domestically manufactured AVK inserts & tools. Available to purchase online or call for custom orders & application solutions.



[ADVANCECOMPONENTS.COM](http://ADVANCECOMPONENTS.COM)

972.446.5500



A-W SERIES

A-K SERIES

A-L SERIES

A-L SERIES

A-H SERIES

A-T SERIES

**IN STOCK & READY TO SHIP**

**Order online & save 5% on orders over \$100**

**ADVANCECOMPONENTS.COM**



**972.446.5500**



# AMPG

## NO SUPPLY CHAIN PROBLEMS LOTS OF INVENTORY

### MADE IN INDIANAPOLIS

- Over 40 of the latest generation Lathes up to 3-1/2" diameter
- Over \$1,000,000 in raw materials on our floor at all times
- 24/7/365 lights-out manufacturing
- Print-to-part manufacturing



AMPG  
www.ampg.com



Search our beautiful fasteners at [ampg.com](http://ampg.com).

8090 Woodland Drive | p: 317.472.9000  
Indianapolis, IN 46278 | f: 317.472.9010

# AMPG

**HARD-TO-FIND & SPECIALTY FASTENERS**

# IN STOCK



**BINDING  
POSTS**  
*(Hex Bolts)*



**SHOULDER  
BOLTS**



**SCREWS  
& BOLTS**



**WASHERS  
& SHIMS**



**NUTS**



**PINS**



Search our beautiful fasteners at [ampg.com](http://ampg.com).

8090 Woodland Drive | p: 317.472.9000  
Indianapolis, IN 46278 | f: 317.472.9010



**UNBRAKO  
IS 99.3%  
STRONGER.**

# Earnest Machine makes Unbrako stronger.



How can we help you **today?**



Earnest Machine is the North American master distributor of Unbrako Premium Socket products. With an industry leading 99.3% distribution performance rate, Earnest makes selling Unbrako a stronger proposition for distributors like you. **99.3% stronger to be exact.**

#### **Unbrako Premium Socket Screws are...**

10,000 psi stronger than competitive socket products.

Manufactured to exacting tolerances and quality you expect from the brand.

The most complete line of premium socket products priced to maximize margin.

#### **Earnest Machine offers...**

Same day shipping of in-stock parts. Drop shipping and blind drop shipping available.

On-demand purchasing eliminates inventory carry costs and allows you to buy product as you sell it.

Reduced acquisition costs with distribution from Indianapolis and Atlanta.

A guarantee you will get the right part, in the right quantity, on-time, everytime.

**Inquire today at**  
**1-800-EARNEST** (1-800-327-6378)  
**or visit**  
**EarnestMachine.com**

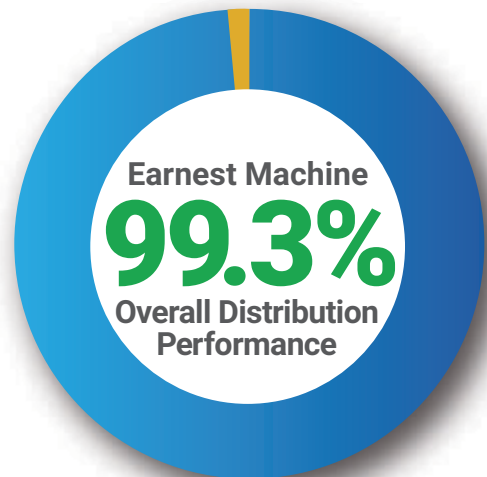

2019 distribution performance average for parts accuracy, order entry accuracy, quantity accuracy and on-time delivery.

BACKED BY THE EARNEST

**Service**  
GUARANTEE

**The right part.**  
**The right quantity.**  
**On-time.**  
**Everytime.**

# FOR **ALL** THE INDUSTRY, IN THE **HEART** OF MANUFACTURING

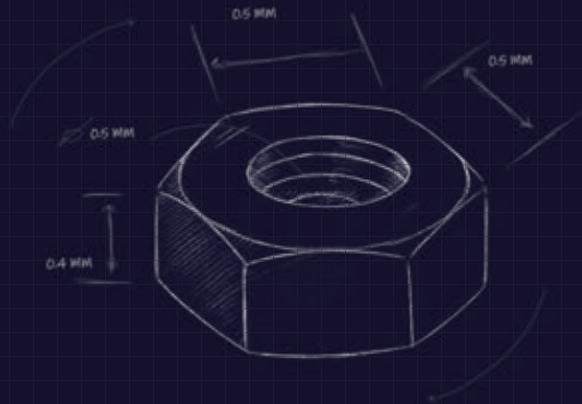

After extensive internal and external consultation and monitoring of the COVID-19 pandemic, we have made the decision to postpone Fastener Fair USA to July 13-15, 2020 at the Charlotte Convention Center.

Fastener Fair USA is the only exhibition in the U.S. dedicated to the full supply chain—distributors, mechanical and design engineers, purchasers, wholesalers, and End -Users/OEMS—spanning key vertical industries. The third annual Fastener Fair USA will be held in Charlotte, NC, putting the show in one of the biggest manufacturing hubs in North America. Visitors can expect a comprehensive display of industry innovation with highly relevant education and unmatched opportunities to connect with peers and industry experts.

**NEW DATES ANNOUNCED!**

**JULY** 13-15  
2020

CHARLOTTE CONVENTION CENTER  
CHARLOTTE, NC



**FASTENER2020.COM/NFDA1**

**COMPLETE MACHINE SHOP • RAPID PROTOTYPING**

# ENGINEERING SUPPORT FROM PRINTS TO PARTS

**BACKED BY NATIONWIDE IN-FIELD TECHNICAL SUPPORT**

**HUGE SELECTION**

**MASTER DISTRIBUTOR**

Get high quality parts in low minimums at competitive prices to help you maximize profit without carrying inventory

**ENGINEERING ASSISTANCE**

- Custom Quoting
- Manufacturing
- Sourcing
- Packaging
- GS1 Barcoding
- Marking / Labeling
- Assortments / Kitting
- Quality Assurance
- EDI



**EASY ONLINE ORDERING**

**SECONDARY OPERATIONS**

**ORDER TRACKING**

**SHORT RUNS WELCOME!**

**FREE CERTIFICATIONS\***

**FASTENERS • GREASE FITTINGS • ENGINEERED FASTENERS  
RAW MATERIALS • LIFTING HARDWARE**



**LOOKING FOR A CUSTOM SOLUTION?**

Contact your G.L. Huyett Sales Representative today at [huyett.com/SalesTeam](http://huyett.com/SalesTeam)

[sales@huyett.com](mailto:sales@huyett.com)

785-392-3017

ISO 9001:2015 Certified

**LOW MINIMUMS • GREAT PRICES • EASY ORDERING**

**HUYETT.COM**

Get 5% Off Web Orders Over \$100\*



\* Some Exclusions Apply

## A CUSTOM CHALLENGE:

A medical supply company challenged us to assist them in creating a small quantity of locking mechanisms that would allow a threaded ring pull pin to be locked in an open or closed position.

## WITH A CUSTOM SOLUTION:

G.L. Huyett's sales, engineering, and manufacturing teams worked with our customer to develop a corrosion resistant, cost-effective, custom manufactured, hex-shaped collar that could be quickly added to or removed from the original ring pull pin and securely locked in position with a set screw.

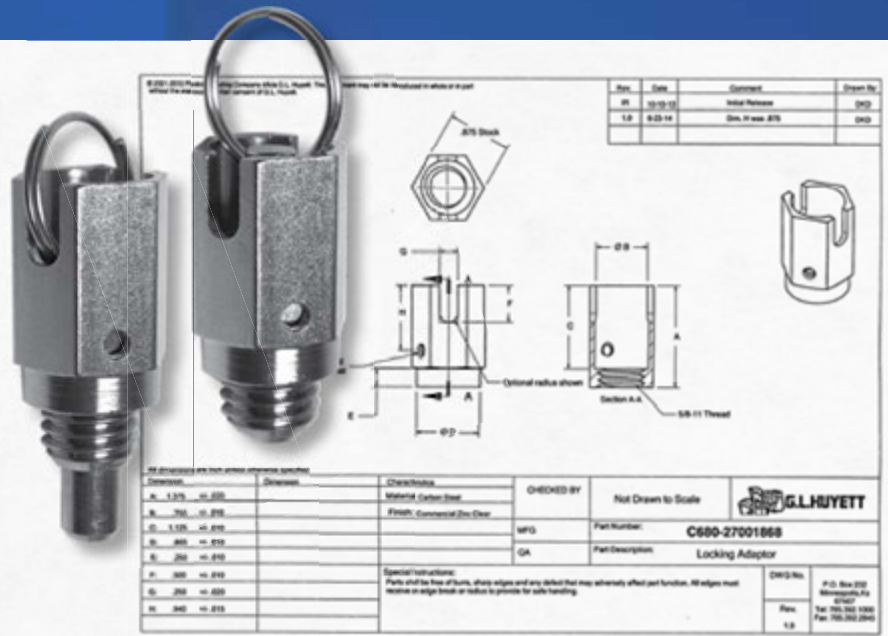

PINCH-RELEASE BOLT RETAINER

## OTHER CHALLENGES AND SOLUTIONS:

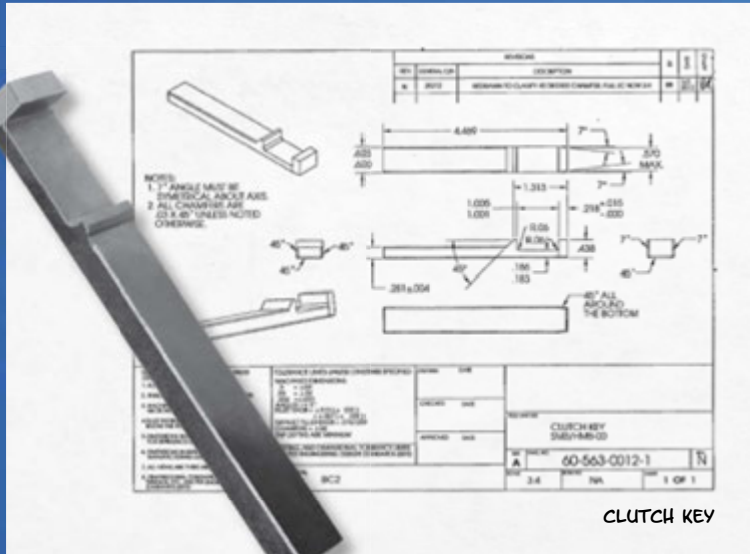

CLUTCH KEY

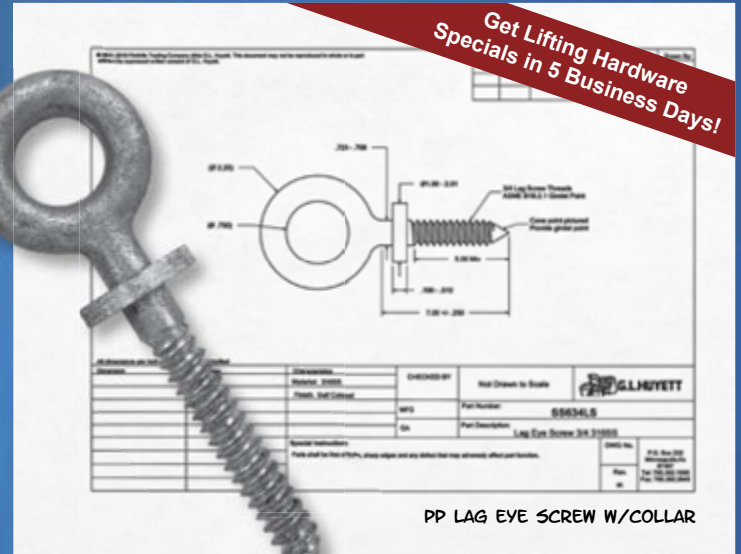

PP LAG EYE SCREW W/COLLAR

Get Lifting Hardware  
Specials in 5 Business Days!

**VISIT HUYETT.COM TO DISCOVER WHAT WE CAN DO FOR YOU!**

## MANUFACTURING CAPABILITIES



Centerless Grinding



Surface Grinding



Milling



Turning



Forming



Laser Cutting



Marking



Stamping



Wire Forming



Tumbling



Drilling



Sawing

# Bringing the industry together since 1981

The International Fastener Expo connects vendors and buyers of industrial products, fasteners, machinery, tooling and related product categories, at the region's largest trade show of its kind. Top industries that attending companies serve include industrial, construction, automotive, truck & bus, and aerospace.

92%

EXHIBITORS VIEW IFE AS AN IMPORTANT ASPECT OF THEIR BUSINESS GOALS

5,000+  
ATTENDEES

62%

ATTENDEES WERE EXECUTIVE MANAGEMENT OR BUYERS/SOURCING

100,000+  
NSF

**INTERNATIONAL  
FASTENER  
EXPO 2020**

September 28-30, 2020  
Las Vegas, USA

**INQUIRE TODAY**

about your booth space  
at [bit.ly/NFDA-INQUIRE](https://bit.ly/NFDA-INQUIRE) or  
email [info@fastenershow.com](mailto:info@fastenershow.com)

