



NFDA TODAY

YOUR NATIONAL FASTENER NEWS



PRESIDENT'S MESSAGE

Nick Ruetz

Our first 70-degree day of the year. It's about time. I'm no weatherman, but it looks like we've turned the corner and the warm weather of summer is on its way.

Speaking of summer in the Midwest, registration is open for the NFDA Annual Meeting which will take place in Chicago June 13-14 at the Radisson Aqua Blu. I hope to see many of you in attendance for networking and industry insights. At the event we will present Carmen Vertullo with the 2023 Fastener Professional of the Year Award. Carmen's passion and devotion in training the future technical stars of our industry came through loud and clear in his nomination. Congrats Carmen!

It's hard to believe that this will be my last newsletter for my term as NFDA president. We will transition to incoming president Jim Degnan of S.W. Anderson at the annual meeting. Additionally, we will take the time

The spring season is upon us. Mother nature has sure had a laugh for us in the upper midwest this year. I write this from our offices in southeastern Wisconsin where just two weeks ago a ten-inch snowfall surprised us. There are still northern parts of our state, Minnesota, and into the Dakotas that are still under several feet of snow. Today, however, we are enjoying

to recognize several Board members whose terms are ending. I'd like to recognize those individuals for their contributions during their terms now as well. Kevin Godin of AFC Industries will conclude his term as Immediate Past President, Kelly Charles of SEMS and Specials concludes her term after serving as Board member and Associate Chair, and Jon Queenin of Specialty Bolt & Screw wraps up his Board term as well. Thank you, Kevin, Kelly, and Jon for your dedication to our industry and service to the NFDA.

We will welcome new Board members in June and get to work on the three-year strategic plan that came together at our session in February in Austin, TX. I appreciate everyone who took time to fill out the survey the NFDA sent out to help inform the planning committee about what is most important to the membership. More on the full scope of the plan to come, but I will share some common themes we took to heart that arose from the survey. Those themes centered around membership value, learning content, and help in today's difficult talent market. I have all the confidence in the world in the Board and committees that together we will continue to reinvent our organization to best serve our membership.

Finally, a word of thanks to the committees that really drive the association. To those of you who serve the Learning, Member Value, and Marketing Committees we thank you for your time and effort into making the NFDA what it is.

See you in Chicago.

WELCOME NEW NFDA MEMBERS

AFI INDUSTRIES, INC.

<https://afiindustries.com>

BUMAX

<https://www.bumax-fasteners.com>

**WING-HAMLIN
COMPANY, INC.**

<https://wing-hamlin.com>



ASSOCIATE CHAIR'S MESSAGE

Mike Robinson

16-17, and then the summer gets kicked off with our NFDA Annual Meeting in Chicago on June 13-14!

We are excited about teaming up with Midwest Council for Children with Disabilities (MCCD) on Monday June 12 for its annual fundraiser at Maple Meadows in Addison, IL, just before the start of the NFDA Annual Meeting. On Tuesday June 13 we are kicking the day off with an architectural river cruise. If you have never been on one of these in Chicago, I highly recommend it! On

Wednesday you will get to see who the well- deserved Fastener Professional of the Year Award gets presented to, along with the ITR Economics presentation, NFDA legend Jim Ruetz presenting on his Ph.D. thesis on family-owned businesses, and ending the event with a participant favorite industry panel discussion with some fastener veterans.

Wednesday you will get to see who the well- deserved Fastener Professional of the Year Award gets presented to, along with the ITR Economics presentation, NFDA legend Jim Ruetz presenting on his Ph.D. thesis on family-owned businesses, and ending the event with a participant favorite industry panel discussion with some fastener veterans.

The Annual Meeting is one of NFDA's best events every year. If you are looking to get more out of your NFDA membership or curious what NFDA can do for you or your company, I encourage you to come to Chicago for this in-person event and experience what makes NFDA such a great association. You will see old fastener friends and have the opportunity to meet new ones as well. All you have to do is show up.

Before we know it, we will be talking about the NFDA Executive Summit out in Scottsdale, AZ this fall. If you have any suggestions for education content or suggestions for the Executive Summit, please email me at mrobinson@starstainless.com.

I wish everyone safe travels and enjoy the rest of your spring. Looking forward to seeing all of you in Chicago this June!

NFDA CALENDAR

Visit the NFDA website at www.nfda-fastener.org for more information

JOIN US FOR THESE UPCOMING EVENTS:

- May 11, 2023** NFDA / YFP Virtual Roundtables: The Triple Bottom Line
- June 13-14, 2023** Annual Meeting – **Chicago, IL**
- September 28, 2023** CEO / Executive Virtual Roundtables
- October 25-27, 2023** Executive Summit – **Scottsdale, AZ**
- November 30, 2023** Virtual Program
- December 14, 2023** NFDA / YFP Virtual Holiday Celebration



NFDA STANDARDS ACTIVITY UPDATE Q1 2023 — John Medcalf

In spite of tech sector layoffs, a theme that continues to prevail in industry is having more available work than people. This certainly remains the case in the area of fastener standardization, with many significant standard revisions tabled waiting for available resources. And with hybrid or web meetings still being the norm, there has never been an easier time to start participating and provide meaningful contributions. I would encourage all readers of this column to consider if you or someone in your organization could volunteer some time to one of the organizations listed below. I am sure that the individual and the organization would realize many benefits that are well worth the time investment. Brief descriptions of current activities are as follows.

ASME

The long-anticipated revision to ASME B18.6.3 on machine screws and tapping screws went through balloting and received several comments and negatives. ASME B18.3 on socket products was balloted to reintroduce spline drives along with some other minor changes, and it received some negatives as well. Both standards, along with the open revision to B18.21 on washers, are expected to be discussed at the next B18 committee meeting. This will be held as a web conference on May 24.

ISO

There are still a number of projects in the works, but current ballot activity has been limited to some minor updates on groove pin standards and the series of all-metal and nylon-insert locknut standards. Both groups of documents are in the early draft stage of ISO balloting.

ASTM

A number of standards are under review, with some of the projects as follows. Ballots are out for the inclusion of low head sockets in the F835 (alloy steel), F879 (stainless steel) and F468 (non-ferrous) specifications. Both F3393 on zinc flake coatings and A563/A563M on nuts are being balloted with a number of refinements to better clarify coating requirements. The F16 committee meetings will once again offer in-person and web attendance, with the physical meetings being held in Denver on May 8-9.

SAE

The task group working on the comprehensive revision to the J429 standard on mechanical properties of externally threaded inch fasteners has a draft that is nearly ready for initial balloting. Some significant updates proposed include provisions for reduced loadability fasteners and an associated marking system not previously addressed and the potential elimination of Grades 1, 5.2 and 8.2. Descriptions of testing requirements have been greatly expanded, and cross-sectional hardness and optional impact testing are being considered for addition.

Please email your standards related comments, concerns, or questions to John at standards@nfda-fastener.org

Communication between NFDA members and the NFDA technical standard representative (the "Representative") through email or otherwise is provided by NFDA as a courtesy to its members. NFDA provides no assurance as to the accuracy, completeness, or timeliness of any statement made by the Representative to the member or fastener technical standards organizations. Neither NFDA nor the Representative makes any representation as to whether any statement of the Representative is consistent or compliant with fastener technical standards. Neither NFDA nor the Representative shall be responsible for any loss or damage suffered by the member or any other person as the direct or indirect result of any statement made by the representative.

John Medcalf's appointment as the NFDA technical standards representative allows the NFDA membership not just visibility of standards activities, but also a voice in the process. NFDA members are encouraged to express their comments or concerns relating to fastener standards. The only way to influence the process is to stay engaged and participate. Please email your standards related comments, concerns or questions to John at standards@nfda-fastener.org

MEMBERS CAN:

- Inquire about changes to drafts noted in quarterly reports
- Ask general standards related questions
- Raise suggested revisions or technical updates to standards
- Offer feedback to continue refinement of these articles



ADVERTISE WITH NFDA

Interested in having an ad in the next issue of NFDA Today? Contact Amy Nijjar to make the arrangements: amy@nfda-fastener.org or 562-799-5519. You also can view information on our website. Click on Advertising in the menu.

TRAINING OPPORTUNITIES



The Fastener Training Institute® offers the following opportunities to increase your fastener knowledge:

FASTENER TRAINING WEEK:

- **August 21-25, 2023** – Chicago
- **December 4-8, 2023** – Los Angeles

NFDA members receive discounted registration on all FTI classroom seminars. For more information and a list of all FTI events visit www.fastenertraining.org

SCHOLARSHIP FOR FASTENER TRAINING WEEK

The application can be found at nfda-fastener.org/fastener-training-week-scholarship. Apply today!

Each year NFDA awards a scholarship for Fastener Training Week, an advanced technical training program produced by the Fastener Training Institute®.

Applicants are evaluated based on the recommendation from their employer, personal achievements, work experience, and an essay. Identifying information is redacted, so the team members evaluating the applications do not know the names or employers of those applying.

The Fastener Training Week scholarship is a benefit for NFDA members only. The deadline to apply for a scholarship is **JUNE 1**. For more information about Fastener Training Week, visit fastenertraining.org



Amy Nijjar
Executive Vice President
amy@nfda-fastener.org

3020 Old Ranch Parkway Suite 300
Seal Beach CA 90740
562-799-5519
www.nfda-fastener.org



BBI Self Drill Screws
Proferred Drillerz™
"Preferred by professionals"

SUPERIOR METAL PIERCING

FULL LOT
TRACEABILITY

MADE IN
TAIWAN

- ICC-ES Evaluation Report ESR-3231
- Head Mark on Screw Heads for Quality Control
- Manufactured & Tested to Demanding Standards
- Manufactured by ISO 9001 / TS16949 Registered Factory
- All Proferred Drillers Meet or Exceed ASTM C954 and/or ASTM C1513
- 50 lb Heavy Duty Cartons w/Gloss Finish 2-Bits included, (Phillips product only)

All BBI Proferred® screws have tighter tolerances, equaling less wobble factor, Preventing disengagement damage to other assembly parts. Effective torque delivery allows for better seating at installation.

Bugle Head Phillips (BBI # 637)

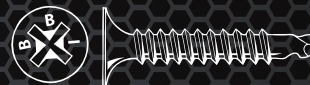

K-Lath Modified Truss (BBI # 636)

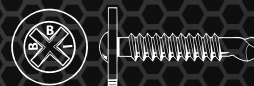

Pan Head Framing (BBI # 064)



BRIGHTON-BEST INTERNATIONAL





Product Focused, Support Driven

- ® Over 20,000 standard parts
- ® Diameters from .100" to 140"
- ® Readily available in assorted platings and alloys
- ® Industry focused engineering

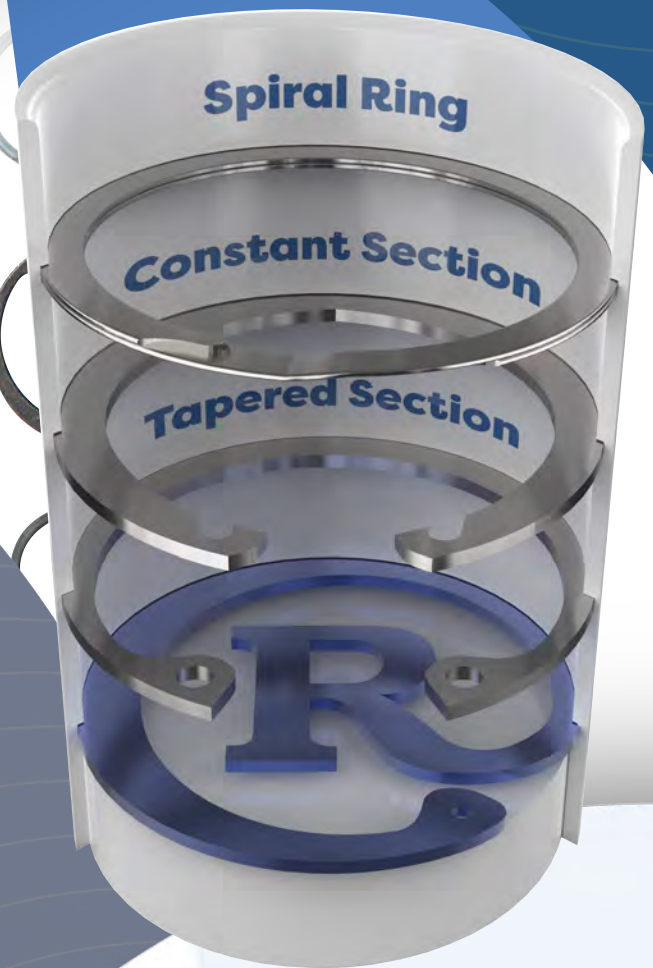

Supply Chain Solutions™

Request
Samples

rotorclip.com

Free Engineering Support:
info@rotorclip.com • +1.732.469.7333

For Distributors ONLY

MADE TO ORDER PROGRAM

SHIPPED WITHIN 7 BUSINESS DAYS

1 PIECE AND UP

Socket Head Cap Screws

18-8 SS, 316 SS, Alloy Steel with black oxide finish
Custom shank lengths and thread lengths

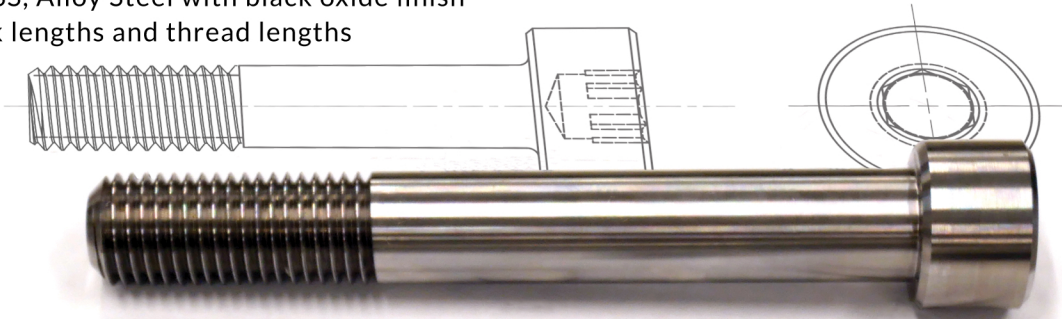

Hex Head Cap Screws

18-8 SS, 316 SS, Alloy Steel with black oxide finish
Custom shank lengths and thread lengths

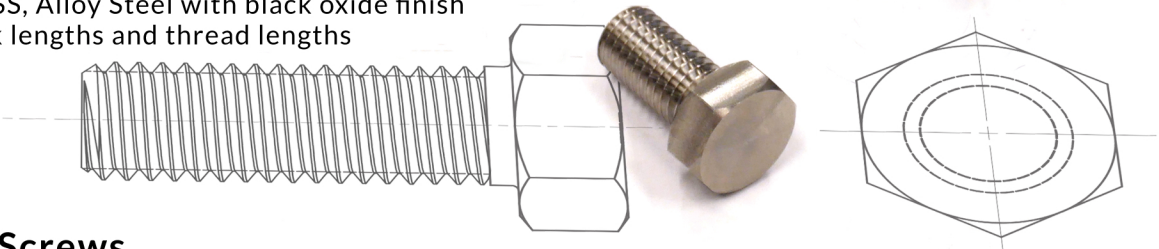

Shoulder Screws

316 SS, Alloy Steel with black oxide finish
Custom shoulder diameters, shoulder lengths and 3 thread choices

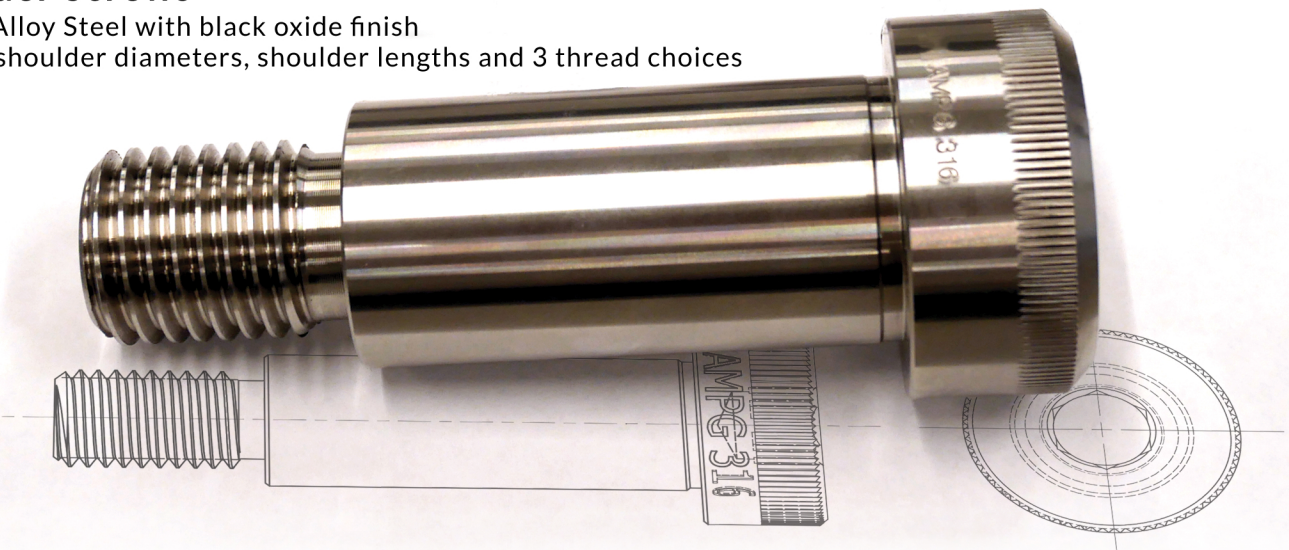

For Fastener Distributors with an authorized Login ONLY. Login and use our Custom Configurator for an instant price and part number. Full CNC manufacturing in Indianapolis.



Search our beautiful fasteners at ampg.com.

8090 Woodland Drive | p: 317.472.9000
Indianapolis, IN 46278 | f: 317.472.9010

THE FUTURE OF **MASTER DISTRIBUTION**

At Brikksen, we are never content with the status quo. We consistently push beyond the standard and deliver exceptional quality that goes **BEYOND** your expectations.





www.fastenerfairusa.com

Join us in the vibrant city of

NASHVILLE



Fastener Fair USA is the only exhibition in the U.S. dedicated to the full supply chain—distributors, mechanical and design engineers, purchasers, wholesalers and OEMs. From automotive to aerospace, construction to HVAC, furniture to appliances, fastener professionals from every segment of the market find the latest products they need at Fastener Fair USA.

May 15: Conference

May 16-17: Exhibit Hall

Music City Center in

Nashville, TN, USA

Register today at fastenerfairusa23.com/NFDA-Web

Use code **NFDA** for a free expo pass

INTERNATIONAL FASTENER EXPO 2023

October 9-11 | Las Vegas, NV

500+ Exhibitors
and 4,500+
Professionals
at the Largest
B2B Expo for
Fasteners,
Tooling, &
Machinery in
North America



fastenershow.com

